

# Tambour Door Cabinet Assembly Instructions

Allow yourself approximately 1 to 1½ hours to assemble your first cabinet. You will require some assistance when aligning components and lifting the cabinet to upright position.

## Tools Needed:

- Phillips head screwdriver. Cordless power screwdriver is a definite plus.
- Large flathead screwdriver
- Pliers

## Please consider before assembling:

- Where will you be using the cabinet? It is best to assemble closest to final destination.
- What will be stored in your cabinet?
- What will you be accessing the most?
- Will you be sitting or standing while accessing?
- What is the height difference in persons accessing what is stored in the cabinet?

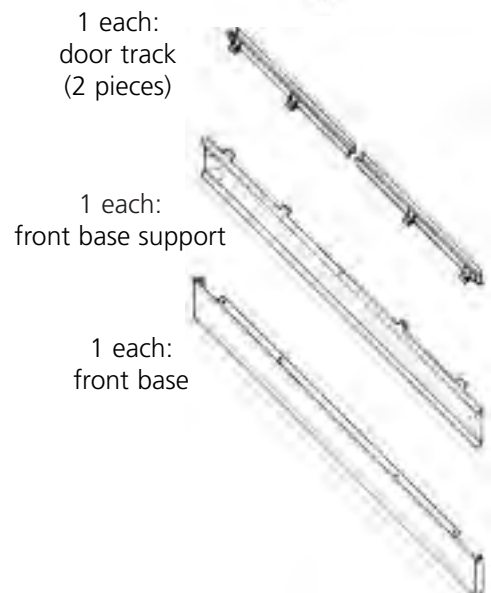
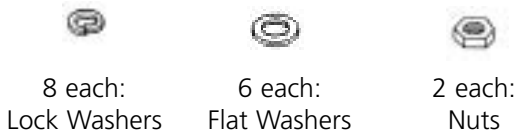
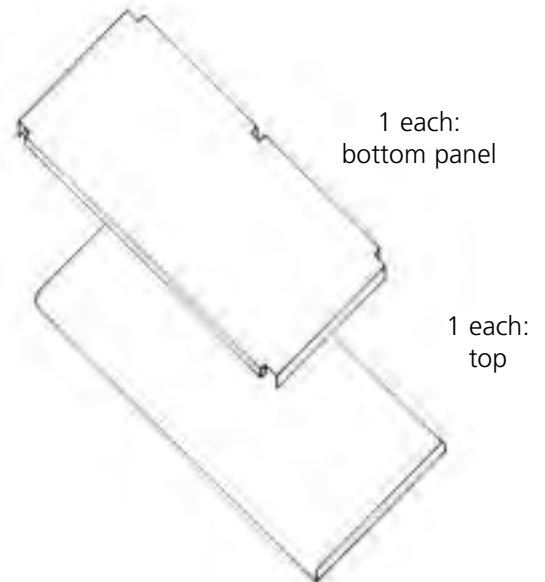
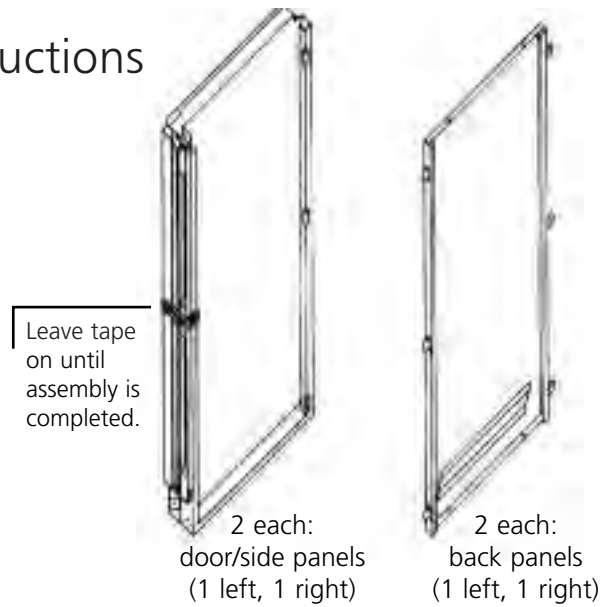

## 1 Assemble Back

1. Lay **Back Panels** on floor with panel that has tabs on both sides to the left.
2. Hook panels together by sliding the 3 metal tabs on the left panel into the 3 slots on the right panel as illustrated in figure 1a.
3. Secure with **Phillips Head Screw** as shown in figure 1b.

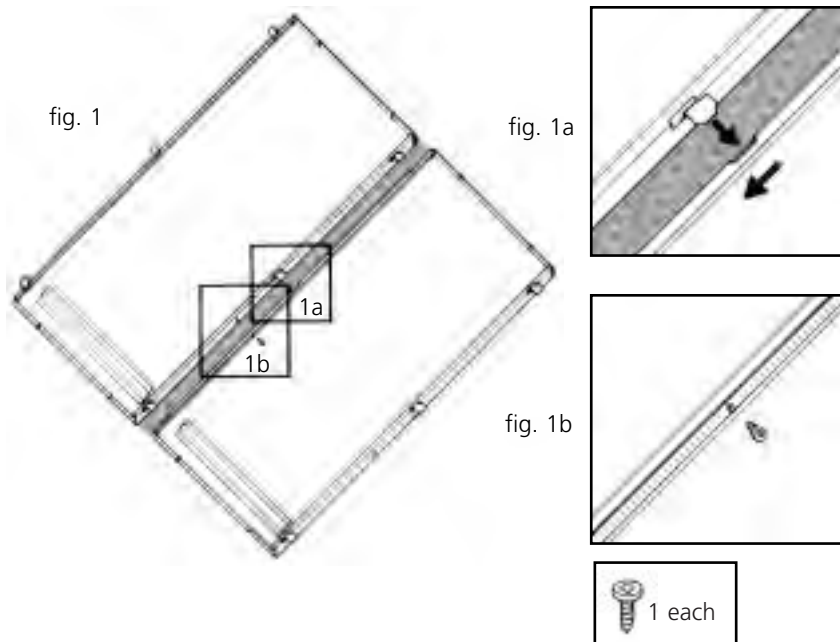

## 2 Attach Doors/Side Panels

1. Next, attach your **Doors/Side Panels**. Place them on the floor on either side of the back panels. The door with the lock should be on your right.
2. Hook the panels together as illustrated in figure 2 by lifting the side panel and sliding the metal tabs on the back panels into the slots on the side panels.
3. Secure with **Phillips Head Screws** on either side as shown in figure 2a.

**Note:** Leave tape on doors/side walls until assembly of cabinet is complete.

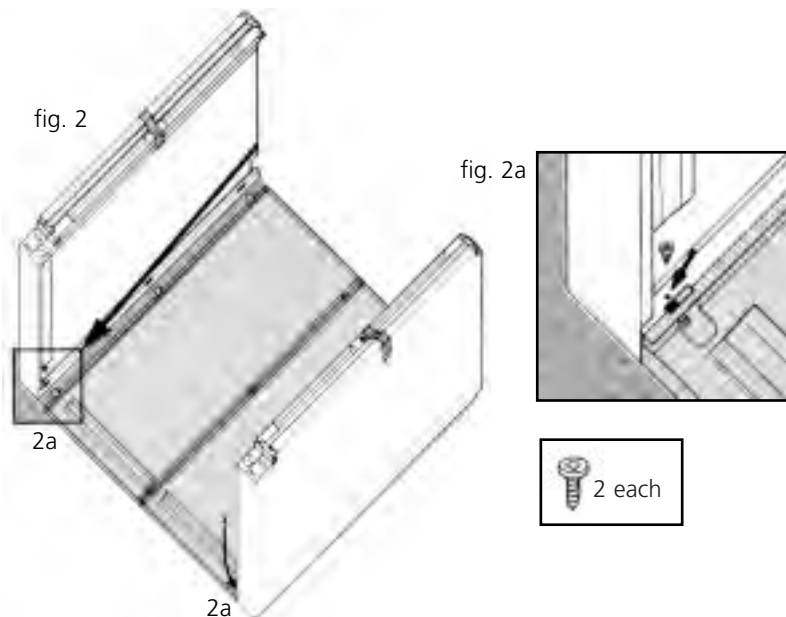

## 3 Install Front Base Support

1. Next, you will attach the **Front Base Support** to the bottom front of the cabinet.
2. The top of the support has two notches. The flat side of the front base support is placed against the flat side of the side panels so that the 6 holes are aligned. (3 on each end) See figure 3.
3. Secure with **Flathead Bolts**, three on each side, as in Figure 3A. Put the **Flat Washer** on, and then the smaller **Lock Washer** on bolts. Tighten bolts securely.

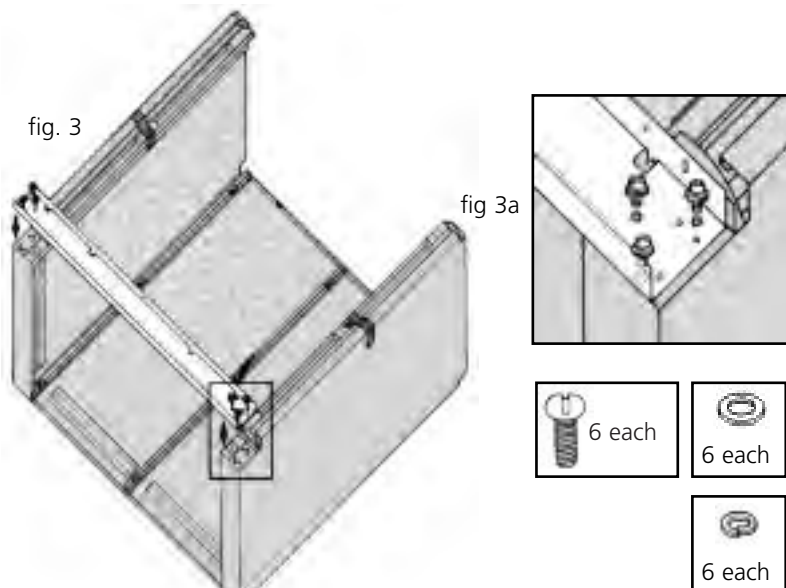

## 4 Install Front Base

1. The **Front Base** is attached by fitting it over the front base support.
2. The top of the front base has seven holes, two are in the center.
3. After fitting on, secure the front base to the center of the front support with two **Phillips Head Screws**.
4. The two screws are inserted from the inside of the cabinet. See figure 4a, and for a cross section view, figure 4b.

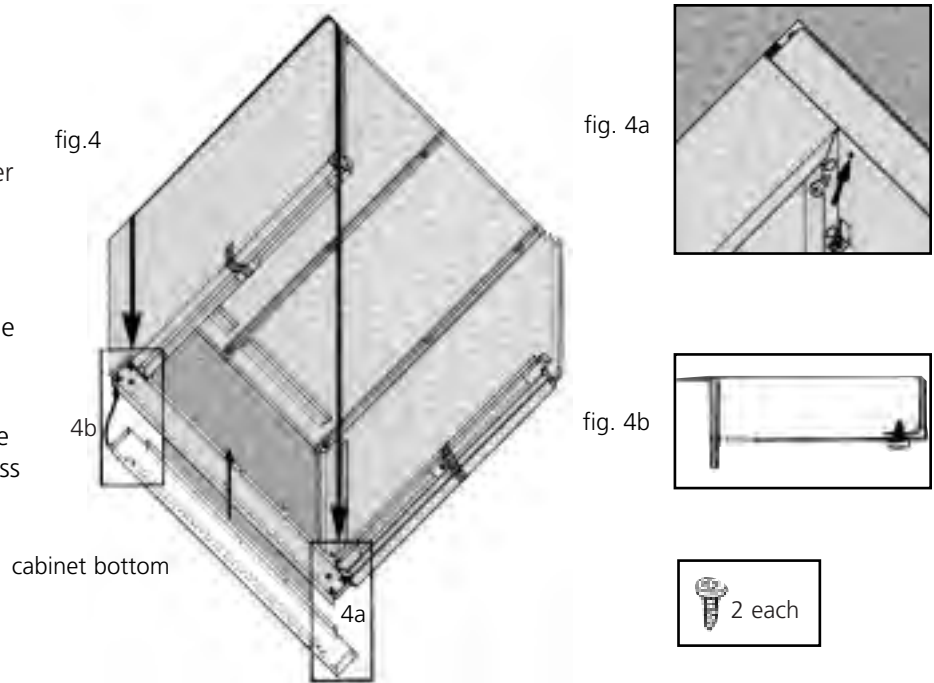

## 5 Install Door Tracks

1. You can now lift your cabinet to its upright position. We suggest two people to perform this task.
2. Place the **Door Track** along the front inside edge of the cabinet with the screw holes facing inward, as shown.
3. Secure the four **Phillips Head Screws** into the holes, making sure that tracks are lining up properly with the sliding doors. The fifth screw is placed in the center where the two tracks meet, as shown in figure 5A.

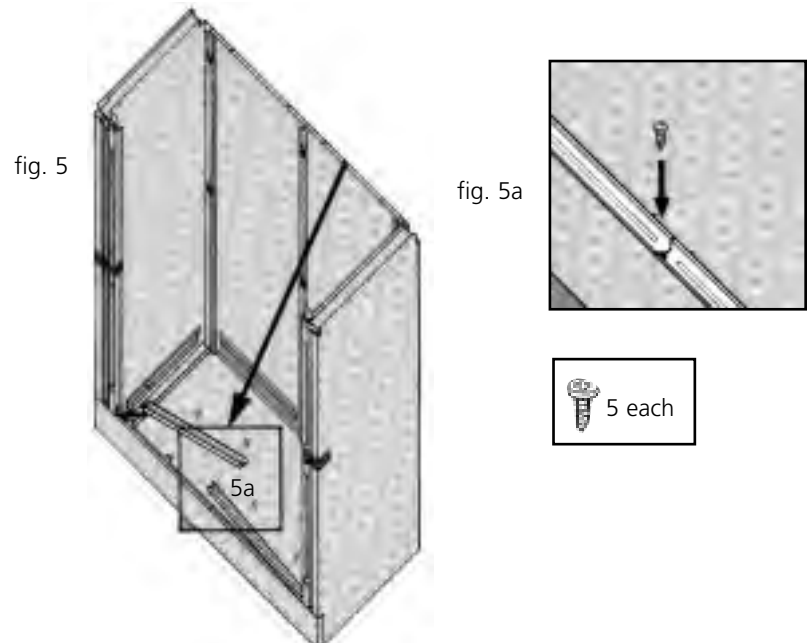

## 6 Install Bottom Panel

1. Now drop in the **Bottom Panel** of your cabinet.
2. The panel should fit in easily, but snugly as this gives the cabinet added support.
3. Angle the bottom panel into position, aligning the center notch in the panel rear with the seam in the cabinet back, then lower the front of the bottom panel into position.

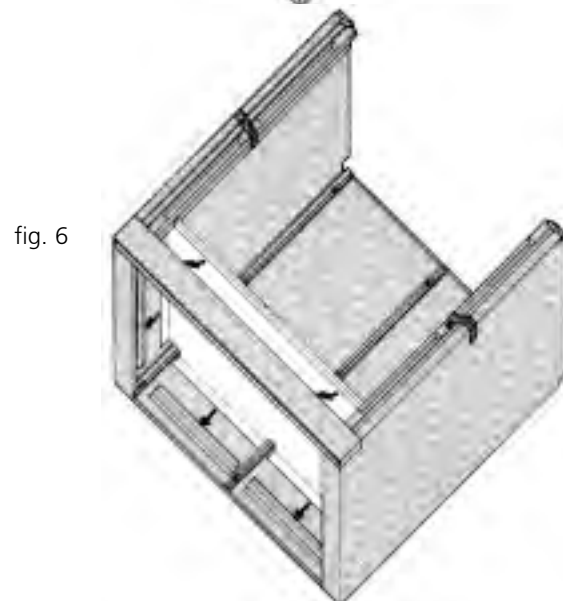

## 7 Install Cabinet Top

1. To fit the **Top** on the cabinet, we suggest one person stand at each side of the cabinet.
2. Lift the top up, and line up the back edge first then fold down onto the cabinet as shown at right.
3. Make any adjustments in order to line up the four screw holes which are on the inside lip of the top panel.
4. First, secure the back of top by inserting the large **Phillips Head Bolts** into the two outer holes as demonstrated in figures 7 and 7a. Fit the **Lock Washer** onto the bolt, then secure with the **Nut**.
5. Next, insert **Plastic Pins** into two inside holes in back lip of top panel as shown in figure 7b.
6. Finally, insert two **Phillips Head Screws** into the forward holes in the sides of the top panel (one on each right & left), as shown in figure 7c.

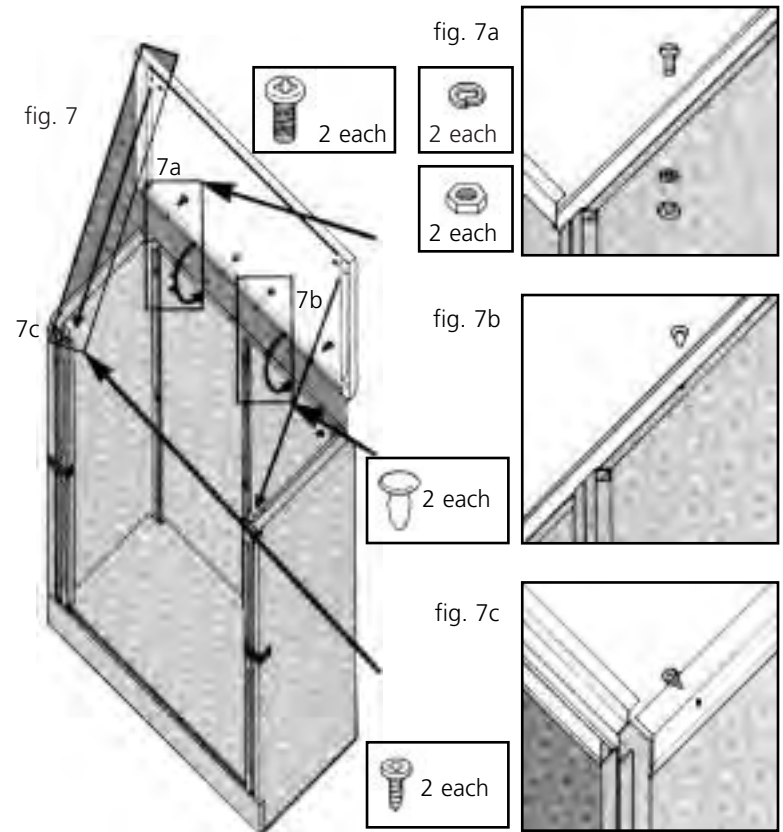

## 8 Congratulations!

1. You are now done with the assembly of your Tambour Door cabinet.
2. Remove tape securing the doors and experience the ease of opening and closing a Tambour Door cabinet.
3. You are now ready to insert/assemble your interior components (separate assembly instructions enclosed)

