

# BASIC FILE CART BFC-1

TOOLS NEEDED FOR ASSEMBLY: PHILLIPS SCREWDRIVER, 1/16" OPEN END WRENCH  
 HARDWARE INCLUDED: 1/4-20 PAN HEAD PHILLIPS SCREWS & 1/4-20 FLANGE NUTS

1.) Assemble angled shelves (if applicable). Attach the angled shelf back to the angled shelf bottom using (2) 1/4-20 flange nuts and pan head Phillips screws. Repeat step for any additional angled shelves.

1/4-20  
FLANGE NUT

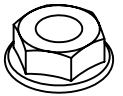

2.) Attach angled shelves to cart sides (if applicable). Angled shelves use the (4) hole pattern on the cart sides (see illustration on right). Use 1/4-20 flange nuts & pan head Phillips screws to secure.

1/4-20  
PAN HEAD  
PHILLIPS SCREW

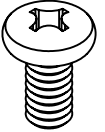

Angled shelf dividers (if applicable). Each angled shelf comes with one divider. Dividers fit into the slots on the angled shelf.

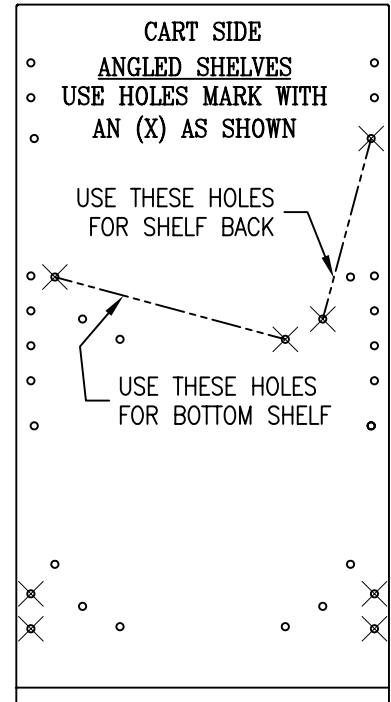
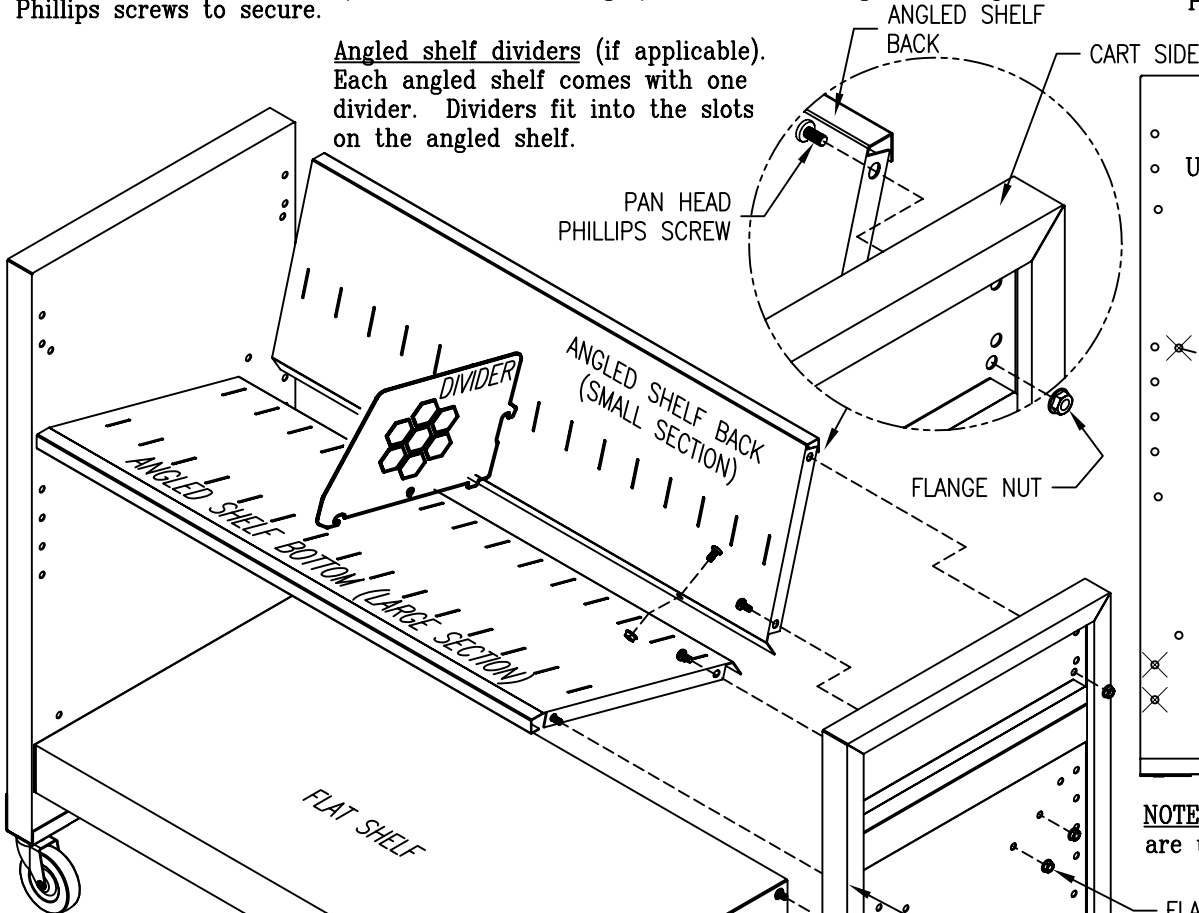

**NOTE:** Remaining holes shown are used for flat shelves only

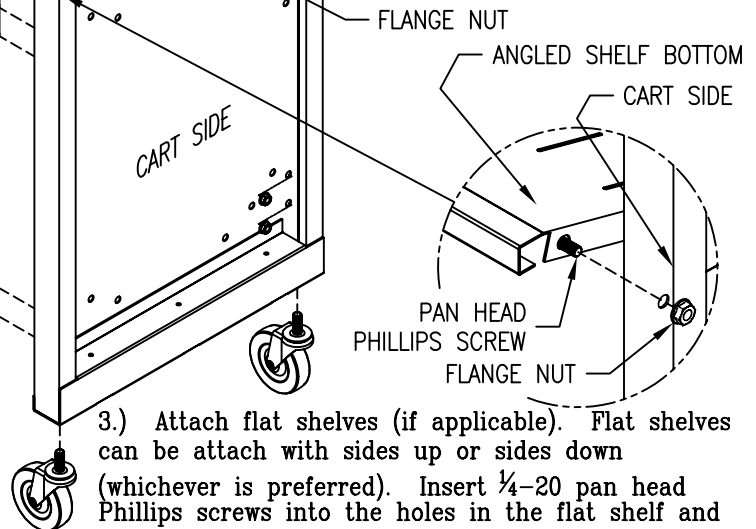
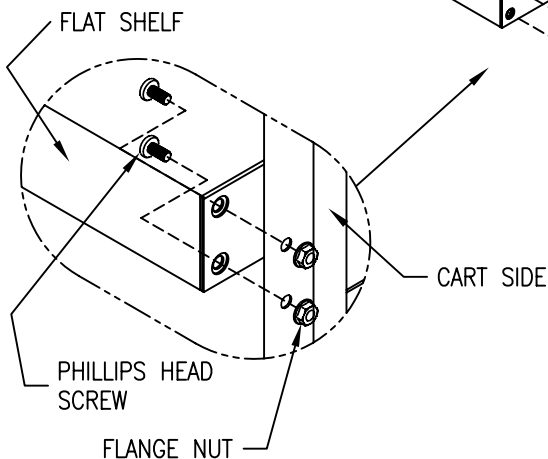

3.) Attach flat shelves (if applicable). Flat shelves can be attach with sides up or sides down (whichever is preferred). Insert 1/4-20 pan head Phillips screws into the holes in the flat shelf and then into the holes on the cart sides. Secure with flange nuts. Tighten screws only after all screws needed have been inserted. Flat shelves require (8) screws and nuts each. Cart sides can accept up to 3 flat shelves.

4.) After cart sides and shelves are assembled, turn unit upside down and insert (4) casters into sockets on bottom of cart.

# BASIC FILE CART BFC-3

TOOLS NEEDED FOR ASSEMBLY: PHILLIPS SCREWDRIVER,  $\frac{1}{16}$ " OPEN END WRENCH  
 HARDWARE INCLUDED:  $\frac{1}{4}$ -20 PAN HEAD PHILLIPS SCREWS &  $\frac{1}{4}$ -20 FLANGE NUTS

$\frac{1}{4}$ -20  
FLANGE NUT

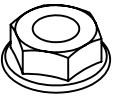

$\frac{1}{4}$ -20  
PAN HEAD  
PHILLIPS SCREW

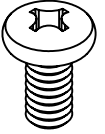

1.) Attach flat shelves. Flat shelves can attach with sides up or sides down (whichever is preferred). Insert  $\frac{1}{4}$ -20 pan head Phillips screws into the holes in the flat shelf and then into the holes on the cart sides. Secure with flange nuts. Tighten screws only after all screws needed have been inserted. Flat shelves require (8) screws and nuts each. Cart sides can accept up to 3 flat shelves.

2.) After cart sides and shelves are assembled, turn unit upside down and insert (4) casters into sockets on bottom of cart.

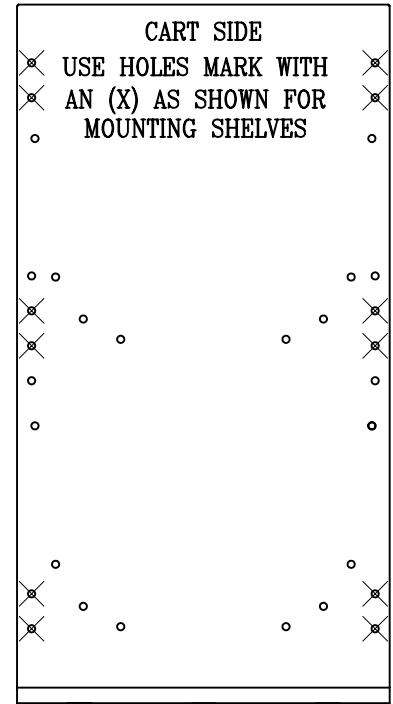
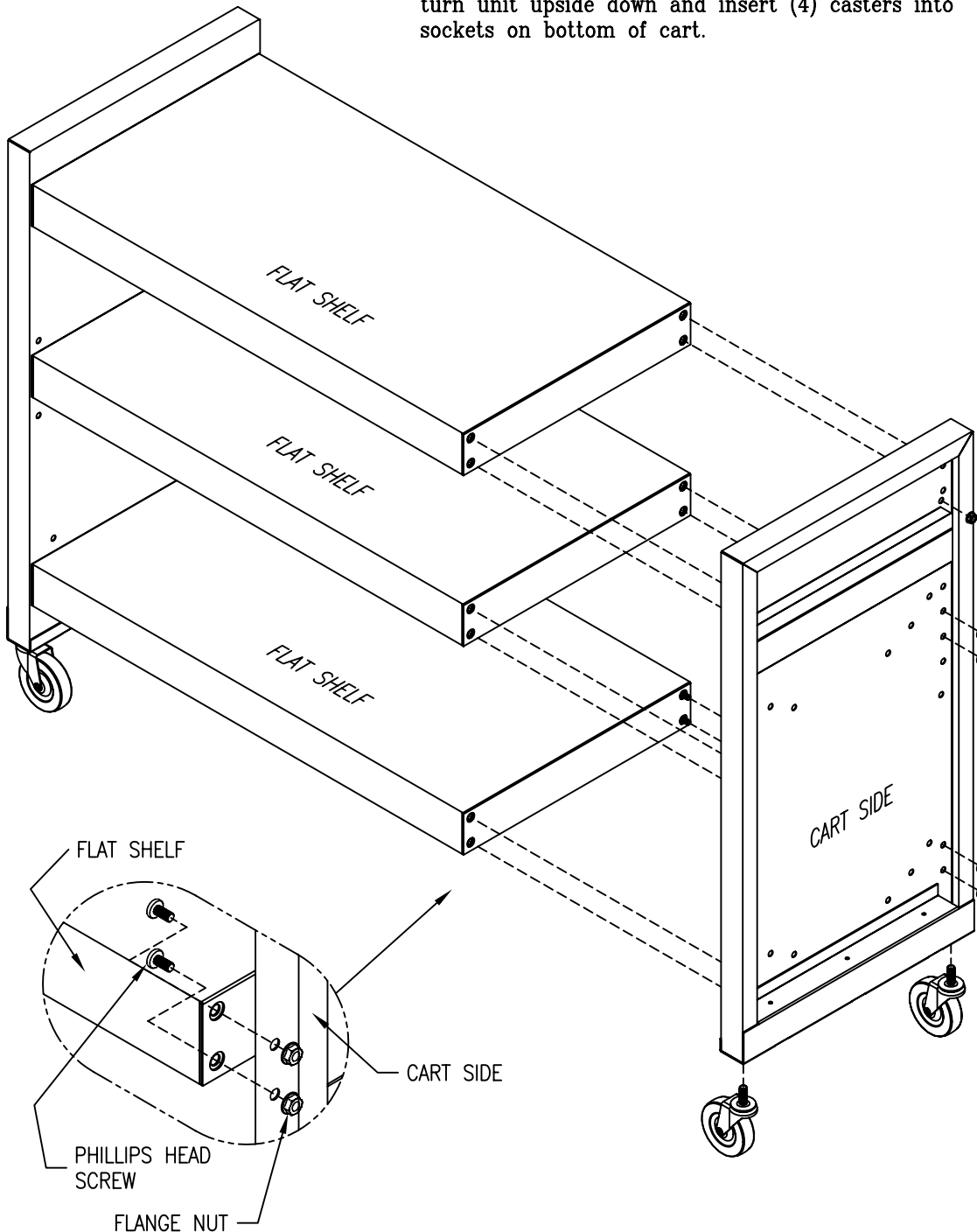

FLANGE NUT

# BINDER FILE CART BFC-5 & BFC-2

TOOLS NEEDED FOR ASSEMBLY: PHILLIPS SCREWDRIVER, 1/16" OPEN END WRENCH

HARDWARE INCLUDED: 1/4-20 PAN HEAD PHILLIPS SCREWS (20), 1/4-20 FLANGE NUTS (20), AND CASTERS (4)

1.) Assemble 2 set of angled shelves. Position shelf back and shelf bottom together and using (2) 1/4-20 flange nuts and pan head Phillips screws. Tighten screws.

2.) Attach 2 sets of angled shelves to cart sides. Attach angled shelves using (8) 1/4-20 pan head screw and (8) 1/4-20 flange nuts (4 per side, per shelf) to the cart sides, do not tighten screws until all 16 screws in both shelves have been started.

Angled shelf dividers. Each angled shelf comes with one divider. Dividers fit into the slots on the angled shelf.

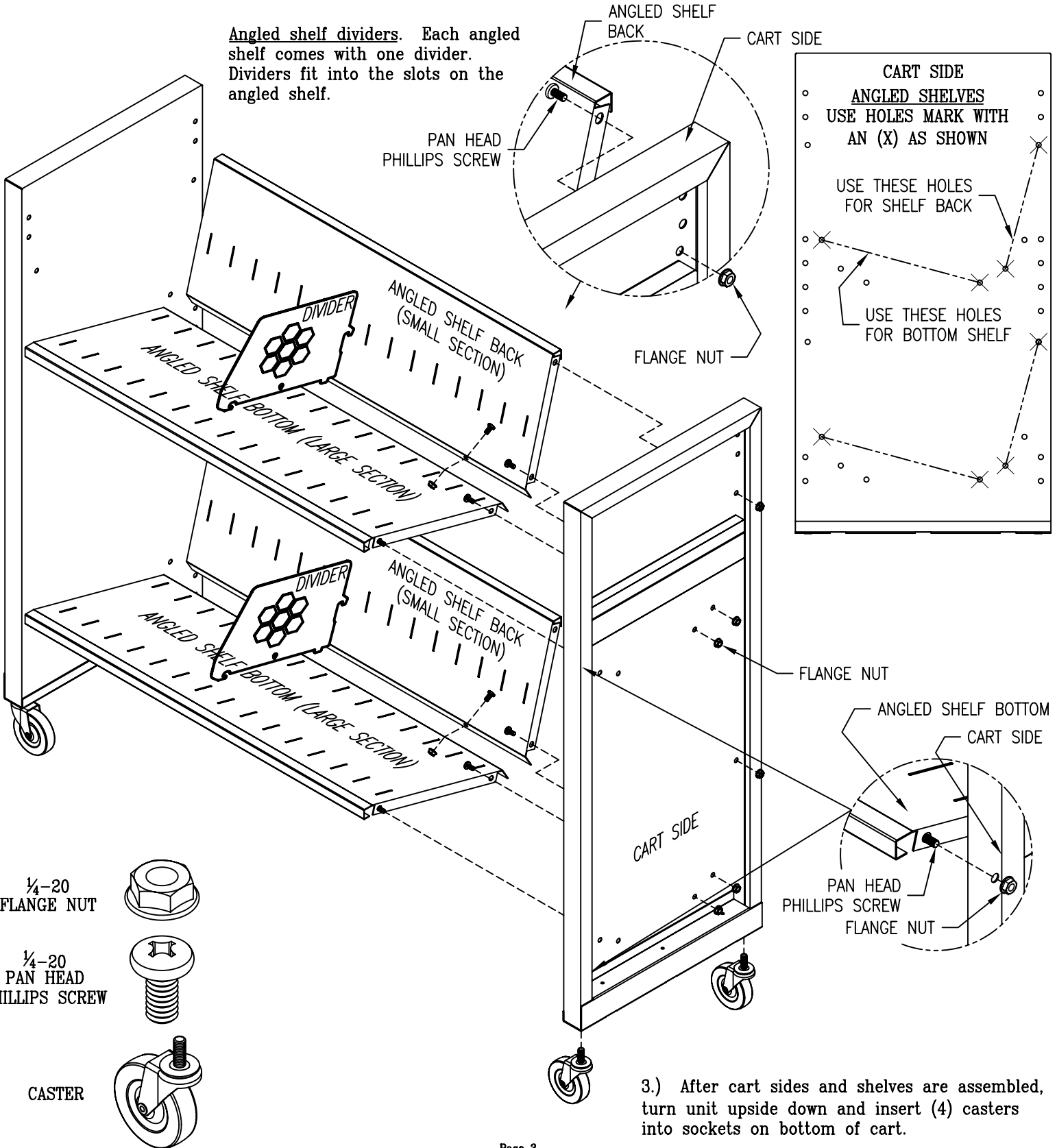

3.) After cart sides and shelves are assembled, turn unit upside down and insert (4) casters into sockets on bottom of cart.

# MINI FILE CART BFC-4

TOOLS NEEDED FOR ASSEMBLY: PHILLIPS SCREWDRIVER,  $\frac{7}{16}$ " OPEN END WRENCH  
 HARDWARE INCLUDED:  $\frac{1}{4}$ -20 PAN HEAD PHILLIPS SCREWS &  $\frac{1}{4}$ -20 FLANGE NUTS

$\frac{1}{4}$ -20  
FLANGE NUT

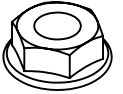

$\frac{1}{4}$ -20  
PAN HEAD  
PHILLIPS SCREW

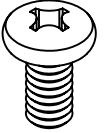

- 1.) Assemble shelves. Attach the shelf back to the shelf bottom using (2)  $\frac{1}{4}$ -20 flange nuts and pan head Phillips screws. Repeat step for second shelf.
- 2.) Attach shelves to cart sides. Shelves use the (3) hole pattern on the cart sides (see illustration on right). Use  $\frac{1}{4}$ -20 flange nuts & pan head Phillips screws to secure.

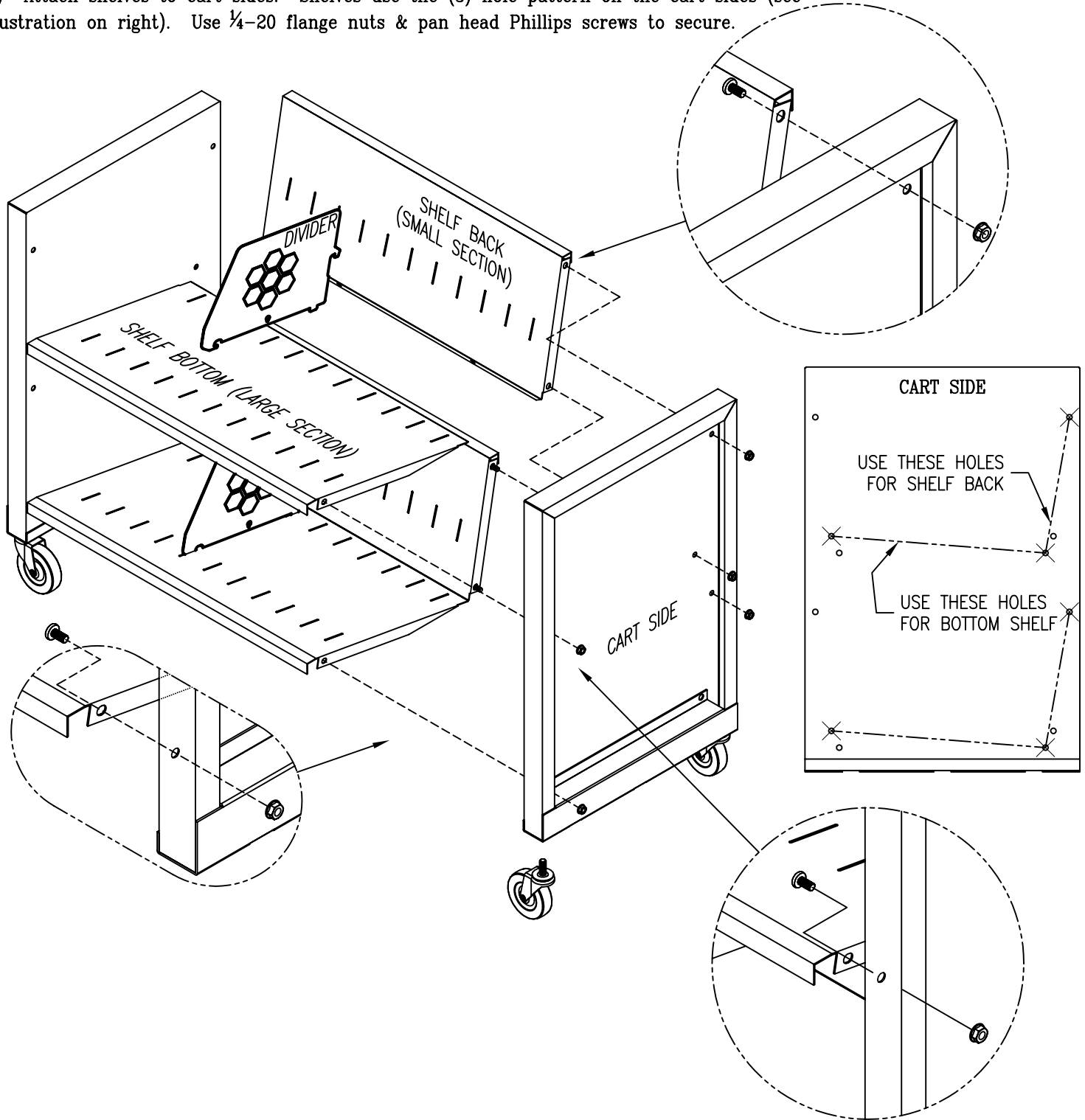

- 3.) After cart sides and shelves are assembled, turn unit upside down and insert (4) casters into sockets on bottom of cart.

# OPTIONAL BASIC FILE CART END PANELS

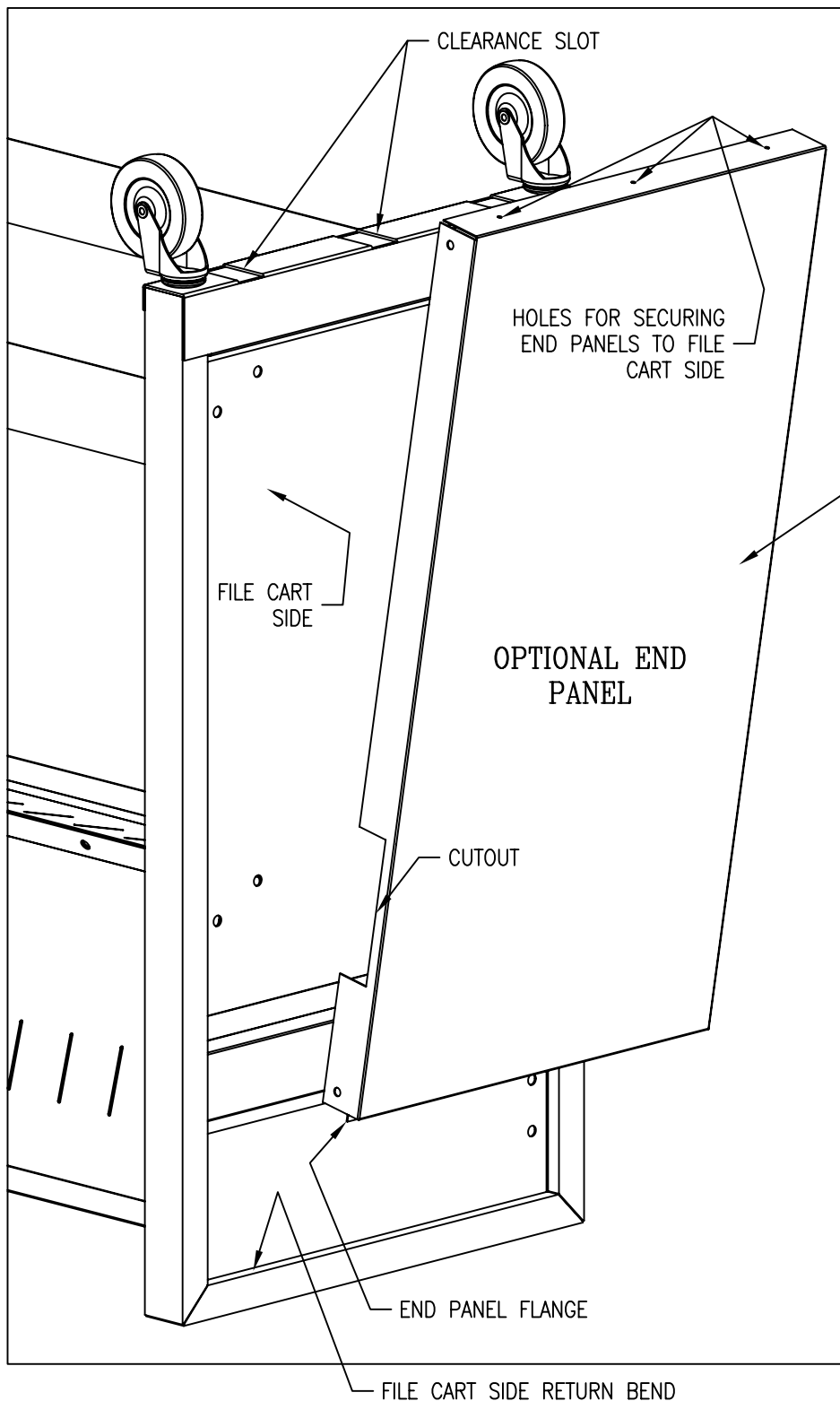

1.) Flip file cart upside down (as shown). Take end panel and with cutout down slide flange on end panel behind return bend on file cart side. Push end panel into file cart side.

2.) Secure end panel to file cart side using (3) #8 x 1/2" sheet metal screws inserted through the clearance slots in file cart side and into end panel.

3.) Repeat steps (1 & 2) for other side of cart.

END PANEL

#8 x 1/2"  
SHEET METAL  
SCREW

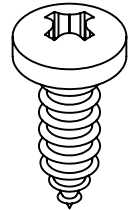

# OPTIONAL LAMINATED/METAL TOP INSTALLATION

1.) Attach 2 mounting brackets to the inner sides of the file cart as shown using (4) 1/4-20 pan head phillips screws & flange nuts per bracket.

## Laminate Top

2.) Place top on top of the file cart laminated side up. Align spot holes on bottom of laminated top with punch holes in mounting brackets. Secure using #10 wood screws.

## Metal Top

2.) Place top on top of the file cart. Align the holes on bottom of top with holes in mounting brackets. Secure using #8 x 1/2" sheet metal screws.

Included hardware:

1/4-20  
FLANGE NUT



#8 x 1/2" SHEET  
METAL SCREW



#10 x 3/4" PARTICLE  
BOARD SCREW

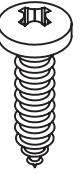

1/4-20  
PAN HEAD PHILLIPS  
SCREW

