

Graphics and Security

Printing Guide

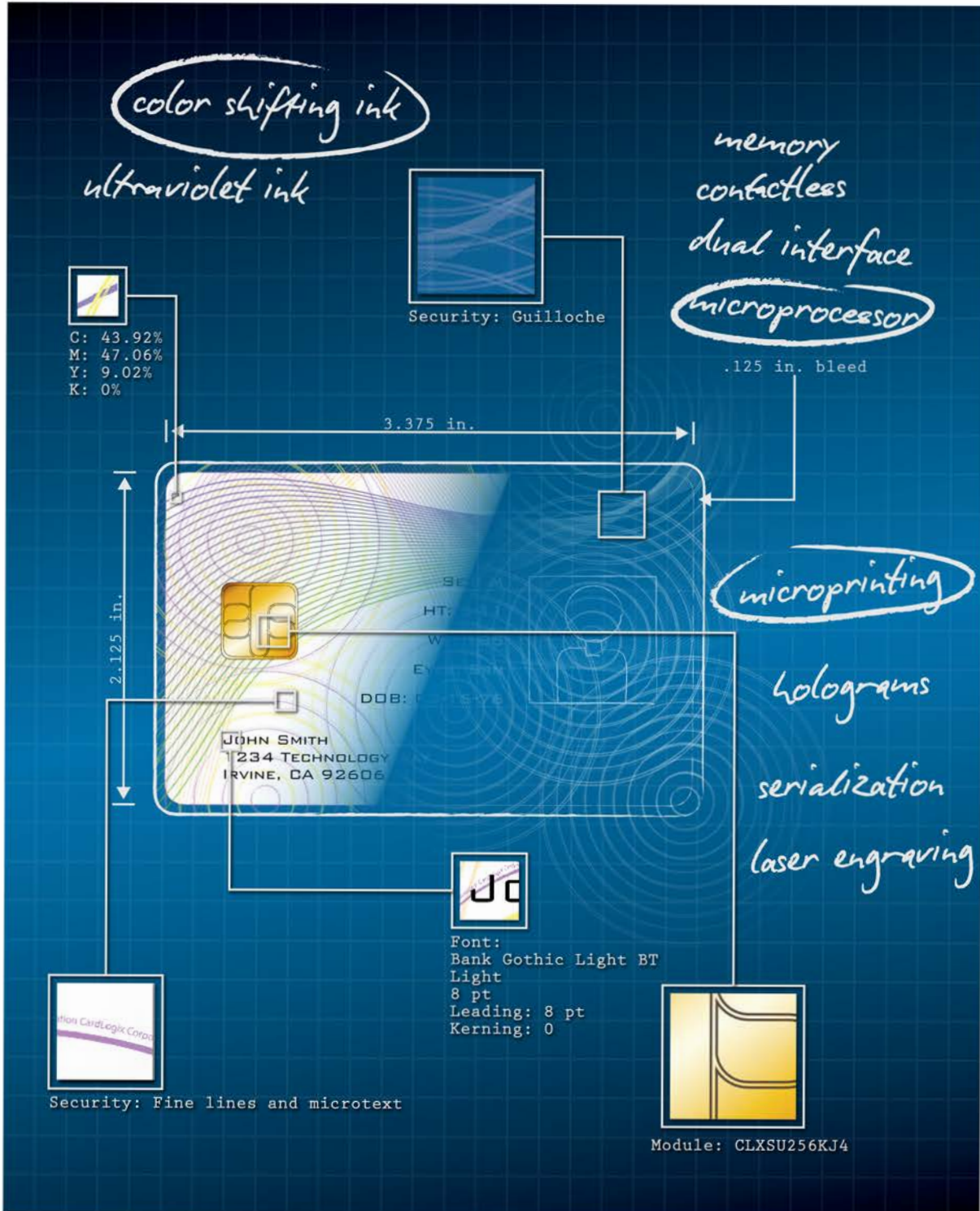

Table of Contents

- Graphics & Security Printing Guide..... 4**
- Ordering & Printing - General CardLogix Guidelines 4**
- Printing Methods Reference Table 5**
- Card Features & Security Options 5**
 - Types of Security 6
 - What's at Stake - Budgeting For Card Graphics Security..... 6
- Production Options 6**
- Design Tips & Suggestions 16**
 - Colors and Fonts Available For Serialization and Variable Image Printing.....16
- Creating Card Artwork 17**
- About Graphic Files and Formats 18**
 - Raster Images18
 - Vector Images18
- Setting Up Your File 18**
- Collateral 19**
 - Carrier Documents.....19
 - Card Sleeves & Envelopes.....20
 - Blister Packaging20
 - Cards With Coupons.....20
 - Other Standard Blister Pack Die Sizes22
- Artwork & File Setup Checklist 24**
- Glossary 25**

Graphics & Security Printing Guide

This guide should be used as a reference when planning, designing and submitting artwork to CardLogix for your order. It offers a basic overview of card, e-Passport, and collateral graphics to help meet your design, security and cost requirements. It will also help you choose the services and features that will suit your unique needs identify and prioritize what you will need to incorporate into your credential, right from the start. A glossary is included at the back of the guide.

The Graphic Aspect of the credential: Text, Graphics, photography and other features that either must be on the card or might be added to improve the card's appearance, functionality, etc.

The Security Aspect of the credential: Graphic elements that help authenticate the card, enabling quick visual verification. These elements are expensive to replicate and difficult to copy, thereby reducing the risk of fraudulent card duplication.

Collateral: Packaging for display or mailing that further enhances the graphic and/or security aspects of the credential.

CardLogix knows that effective graphics are an important element of a successful program. In addition to providing this guide, we have a design ruler and downloadable templates as tools to get your started. We look forward to working closely with you on your design; and remember, if you fall behind, we offer design services as a supplement to your staff. Just ask your CardLogix salesperson for details. This guide is not meant as an all-inclusive discussion of card printing, but rather a general overview to supplement your expertise and familiarize you with how CardLogix works.

Ordering & Printing - General CardLogix Guidelines

Quotations: Quotations are valid for fifteen days and are subject to a final review of artwork and specifications when the purchase order is received.

Terms: Standard terms are 50% of total order value. This payment is due to CardLogix when you place the order, and the balance is due at the time of shipment or Net 30 days upon approved credit application.

Proofs: CardLogix will supply a proof of your card to your specification(s). This proof will help you visualize how your printed card or collateral will appear and give you an opportunity to make any necessary changes or corrections. An additional color-matching proof is available at a nominal charge.

Shipments: In accordance with the Printing Industries of America established trade customs, overruns or under-runs not to exceed 10% shall constitute acceptable delivery, and the excess or deficiency shall be charged or credited to the customer. Exact shipping quantities are available for a 5% premium over the standard price.

Data Security: We strongly recommend that card graphic files be protected when exchanged between your company and CardLogix. Electronic delivery should never be in the clear and should be shielded by simple measures like Pretty Good Privacy™ (PGP) software or password protected Zip files. When physically delivered, a secure courier can be used. These measures are recommended for all but the most low-value card program.

Materials: Standard card material used is a specific PVC (Poly-Vinyl Chloride) material that is compatible with our processes. Other card materials are available on special request and at additional cost. E-Passport datapages are typically made from polycarbonate for longevity and compatibility with laser engraving systems.

Ink Colors: CardLogix can match most Pantone® colors. Slight color variations may occur across a lot, due to variations in materials, inks, processes, heat, lamination, and other factors.

CardLogix Rights To Promotion: CardLogix reserves the right to use all products produced by us in our advertising and promotions unless otherwise directed in writing at the time of the order.

Printing Methods Reference Table

CardLogix employs several different printing methods when producing credentials in order to balance card functionality with production efficiency. Each printing method introduces its own capabilities and limitations, which should be considered when designing the look of your product. The following table describes each printing method and highlights the most important factors for consideration. To achieve a balance between cost and functionality, multiple methods may be used on the same credential. An example would be a card that is printed lithographically to enhance the marketing appeal. However, it uses a dye sublimation (secondary printing) for variable data to be used by the POS system.

Printing Method	Features	Min. Order	Design Considerations	Pros	Cons
Lithography	Four color process with optional Pantone® color matching. Full bleed available on both sides. Available with PVC clear overlay with mirror/mirror or mirror/matte finish.	2500	Metallic inks are considered a separate Pantone® color.	Lowest cost per card when ordered in high volumes.	Longer lead-time and lack of the ability to use variable data.
Screen Printing	Up to seven (7) colors. You can supply your own artwork as a vector file.	500	Provide trapping (.003" - .004") on artistic elements with tight registration. Keep all meaningful elements at least 1/8" from the card edge.	Cost effective for small to medium runs of 200 - 3000 cards.	Low durability and high cost.
Dye Sublimation	Typically used for serialization, photo ID's, barcodes and other one-off types of printed elements. Up to 13 colors, each applied in a single pass at 300 DPI. You may also supply artwork as resolution-independent computer files.	250	All images submitted must be the exact size of the intended print size on the card. Bleed is usually not possible in the dye sublimation process. Artwork must be 1/8" inside of the edge of the card, and a white edge may be exposed.	Allows for limited customization of each card. Also for fast turnaround of smaller runs.	High cost per card. No bleeds, lower durability.
Lenticular Printing	Motion graphics. When the card is tilted the image on the card appears to move. Artwork must be designed and submitted at 600 DPI or higher and at full output size.	50,000	Artwork design can be complex and costly as it requires multiple high resolution image files. Longer production times.	Customer "WOW" factor.	Graphic design complexity and production cost.
CardLogix Card Validator®	Simple, hidden graphics that are revealed by placement of a CardLogix Card Validator® lens on top of the card	5,000	Please use a dark color (black / reflexive blue, etc.) and at least 12 pt font type (preferably larger)	Low cost	Needs a lens
Guilloche/ Microprinting	Extremely fine, difficult to reproduce printing creates high physical security patterns so that the cards cannot be forged. Artwork must be submitted as resolution independent artwork.	10,000	Generating a guilloche will require special computer software or pre-fabricated engravings. All paths must not exceed dimensions of bleed area.	High security, difficult to reproduce.	Graphic design complexity.

*If card has a bleed in it's design, allow 1/8" extra image all around. Do not round off corners. Do not position type within 1/16" of the card edge.

Card Features & Security Options

Many of the following options make fraudulent duplication more difficult, especially when options are combined. The added security of any printing option must be evaluated in terms of functionality, distribution and total cost. Card applications vary in terms of card and program value, ranging from low-value discounts to very high-security access.

No single or combination of any options absolutely guarantees that a credential or document will be fraud-proof, but by adding sophisticated graphic elements that can be used to discourage counterfeiters and forgeries.

Types of Security

Overt (Level 1): Overt security features, or 'sensory' features, are designed to easily identify a credential with little training and no tools. Examples include color-shifting inks, tactile bumps, holograms, latent images, watermarks, and visible security threads. Because they are easily recognized, these are the easiest types of features to validate.

Covert (Level 2): Covert security features are not obvious to the naked eye and require simple tools and/or some training to authenticate a credential. Examples include: fluorescent inks and the CardLogix Card Validator®. Another is an intentional error. These credential features are extremely secure and hard to duplicate, as they require multiple-factor validation and skilled examination. Covert security features offer a good balance of security and ease of verification.

Forensic (Level 3): The presence of forensic security features is well-concealed, and the features cannot be normally detected without highly specialized equipment. An example would be an ink tagged with an unusual and rare material that responds only to a very specific light wavelength.

What's at Stake - Budgeting For Card Graphics Security

Just as in the design of your credential type and functionality, understanding the value of your credential program is essential in setting the level of graphic security for your card. The most common mistake is to save incremental printing costs while leaving to chance the much higher cost of fraudulent card duplication. When building a credential that relies on barcodes or a magnetic stripe, you might consider executing more security features, as these types of cards are susceptible to cloning. Things to consider when budgeting graphics include:

- Loss of customer confidence if security is breached
- Content replacement cost: value (points, currency), or secure access data (passwords).
- Associated costs: programming, artwork, collateral, promotion
- Distribution cost: retail, mailing
- Replacement cost

CardLogix recommends establishing a high threshold of security that discourages attacks, rather than hedging on low security and luck.

Production Options



Card Punching & Die Cutting: Tether or badge holes can be made to accommodate clasps or lanyards. See badge diagrams for badge hole location and specifications. Custom punching of card shapes and drilling is also available. Ask your CardLogix sales representative for details.



Foils & Overlays: Available in either metallic foil or polyester overlays to increase security. Metallized foil comes in roll form and can be any width or length. A small strip with text or an image stenciled out of the foil can be applied to a card for a unique edge-to-edge effect. Alternatively, foil can be cut, shaped, and placed onto any location on the credential. Special tooling charges apply. Low-cost, opposing double stamp foils that create a 'pseudo hologram' are also available.



Hidden Barcodes: Infrared barcodes protect the authenticity of a card by providing a higher level of security to standard barcodes. Barcodes with no security can be easily scanned into a computer or replicated with a copy machine. Hidden barcodes require a special type of barcode reader, and they cannot be scanned or copied by conventional means.



Laser Engraving, Indenting & Ablation: Laser engraving is the process of removing or burning material from plastic in order to create an image, number, or machine readable barcode. Laser ablation has the benefit of more precise control over large areas and depth. This produces a physical characteristic that cannot be easily re-created, removed, or altered. A 10,000 card minimum order applies.



Lenticular Motion Graphics Printing: 3D or Motion graphics are available with a lenticular optical design. This option makes the image on a card appear to move or pop out when the card is viewed from different angles. Large minimum order quantities are required for this style of printing.



Magnetic Stripe: A magnetic-stripe for permanent on-card data storage. Available in 1, 2 or 3 track, low or high coercivity. A magnetic-stripe can be applied to contactless or contact smart cards as shown in the Production Options section. Custom magnetic-stripes are also available in an array of colors and can be made as holograms as well.



Optical Variable Devices (O.V.D's) & Holograms: A holographic film or layer applied to each card. Holograms may have a 3-dimensional effect, color changing properties, etc. O.V.D's can either be embedded in the actual card during production or hot-stamped when the card is finished. Embedded O.V.D's can be made to de-laminate (as an added security feature) when tampered with.



Proprietary Materials & Special Colored Interlayers: Proprietary materials are those manufactured for a specific company, product, or individual. Materials can be metallized foil, pvc/plastics, or specialty items. All proprietary materials are stored in our high security vault. Colored interlayers are layers of colored material sandwiched between two or more translucent layers of laminate that when viewed on the proper plane, change the most prevalent color of the card to the color of the interlayer material.



Scratch-Off Panels: Data that is printed on a card can be temporarily hidden by covering it up with a non-transparent, removable scratch off panel. This is often used to protect PINs and account numbers during mailing or on substrates that reveal a prize item after customer purchase.



Serialization & Variable Image Printing: The printing method used to apply serialization or other variable data to the printed card has a limited number of fonts/barcodes and colors to choose from. CardLogix has the ability to guarantee that no two cards will ever get the same serial number, unless specifically requested. Typically serialization programs are correlated with data that is inserted into the chip. This data is usually supplied to CardLogix as a database file or special instructions from the customer. The tables on the following page list the available fonts and colors. Keep in mind that this restriction applies ONLY to sequential serial numbers or other types of 'one-off' variable data objects that are printed on the card. Standardized text placement positions are available, so check with your CardLogix sales representative. The following barcode types are supported and can be printed directly on the card or collateral as an additional process. These barcodes can represent unique individual and card data e.g. serial numbers. This data can be correlated or extrapolated with data that is loaded in the chips. If your program requires a different format, please let us know and we can add it to our production suite at little or no cost.

- Code 39
- Code128
- Code128C
- PDF417 (2D)



Signature Panels: A writable panel for a user's signature or other written data adding additional security. See the signature panels diagrams for signature panel options and dimensions. Also available are tamper-evident, non-erasable or custom-printed versions.



Tipping & Embossing: Card embossing is available in two American Banking Association-approved point sizes: that found on a credit card, and one other font style. "Tipping" color (either gold or silver) is applied to the embossed type for clarity.



Color Shifting Inks: Many color shifting inks are restricted by the manufacturer, and registered for security reasons. Minimum orders apply. This options can make your card very difficult to reproduce.

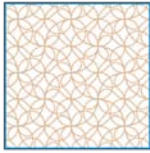

Guilloche: Guilloches are complex geometric patterns that consist of numerous interwoven fine lines. Because each pattern is uniquely generated, exact reproduction is nearly impossible.



Microprinting and Nanoprinting: Microprinting is a printing technique that creates a faint line, composed of very fine text. This text is only clearly legible through a magnifying glass or microscope. It is impossible to reproduce using conventional scanners and desktop card printers.



Ultraviolet (UV) Fluorescent Inks: UV fluorescent ink is invisible in normal light, but glows brightly when exposed to ultraviolet light. It can be used for any printed security feature on a card (graphics, text, etc.). UV fluorescent inks are available in an array of colors.



Validator: Hidden Images are mathematically buried in the printed card and can be viewed with CardLogix's Card Validator® lens. Because of the fine detail used to generate the hidden images, they cannot be scanned, copied, or reproduced.



Variable Laser Image (VLI) or Changeable Laser Image (CLI): This is a feature generated by laser engraving or laser perforation that displays changing information or images, depending on the viewing angle. It is made on a polycarbonate substrate and prepared through a plate lamination process. This process gives the changing image its dimensionality.

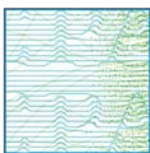

Relief (3-D) Design Medallion: A security background design incorporating an image generated in such a way as to create the illusion that it is embossed or debossed on the substrate surface.

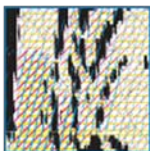

Laser Moiré™ (Blackout): Moiré patterns are incorporated into a graphic design. When replication is attempted, there is severe distortion, producing unmistakable moiré interference patterns throughout the image. In some cases, the reproduction is completely blacked out. As a frontline measure, lenses, such as the CardLogix Card Validator®, are available that reveal the moiré patterns instantly.



EURion Constellation: This pattern of five circles is used on cards, banknotes, ballots, and other credentials and disables reproduction by most color copiers and scanners.



Split Fountain (Split Duct Printing): Also known as rainbow printing, subtly blends colors together in such a way that the transition from one color to another is perfectly uninterrupted, and almost impossible to reproduce. Split Fountain is optimized for traditional offset printing, as digital printing only generally mimics the effect.



Gravure: Gravure is another traditional offset technique that utilizes recessed areas or cells, which form the printed image. Digitally produced, Gravure mimics a dimensional complexity that makes duplication difficult.



Speed Bumps (S Bumps): Tactile printed elements that are raised from the surface of the credential. S Bumps are ideal for rapid validation of a credential.



Watermark: A picture, text or character motif that is incorporated into a card, paper, or substrate during manufacture.

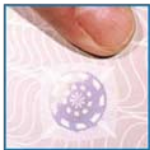

Thermochromic Ink: A thermochromic ink is made up of a specialized ink that changes color with exposure to temperatures, such as body heat.

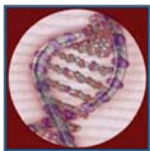

DNA Taggants: These taggants are complex shaped molecules containing compounds that do not naturally occur. When a credential is tagged with ink containing these compounds, it is uniquely identifiable, using forensic equipment.



OV Dot™: These are microscopic nickel particles produced in variable shapes and sizes carrying an e-beam originated high resolution holographic image securing the authenticity of OVDot™. These microparticles are further personalized by a variable alphanumeric code integrated within the structure of OVDot™ itself.

SMART CARD DIMENSIONS

CR-80 Card (8-pin Module)

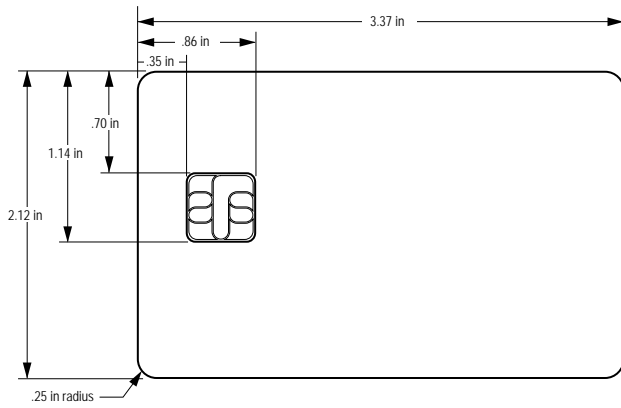

CR-80 Card (6-pin Module)

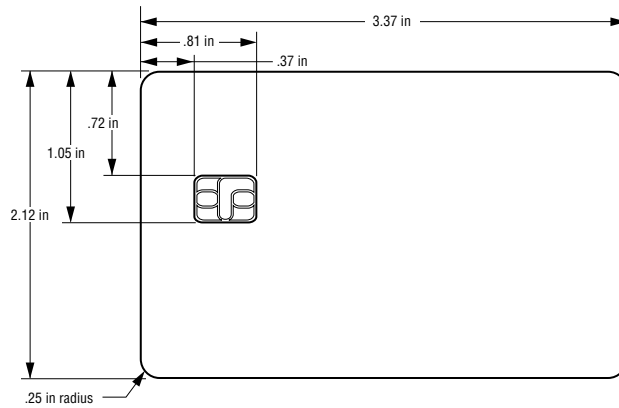

CARD PUNCHING OPTIONS

Option #1 (GSM Punch)

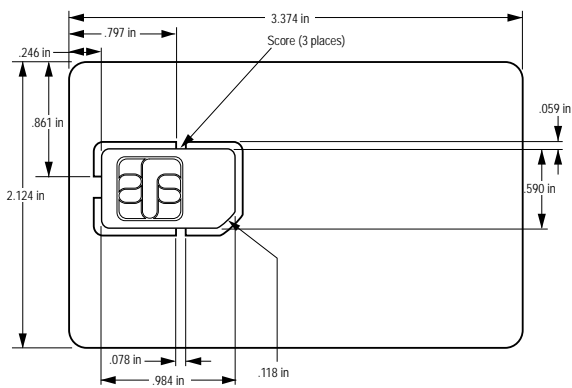

Option #2 (Keychain Punch)

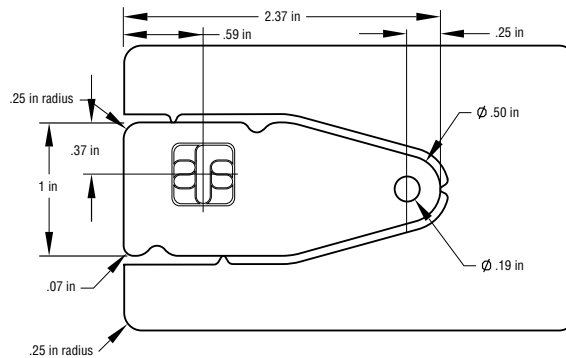

Option #3 (Landscape Badge)

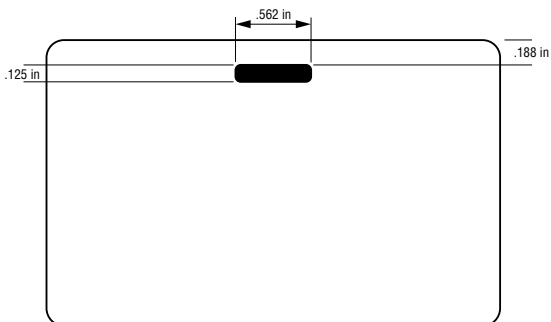

Option #4 (Portrait Badge)

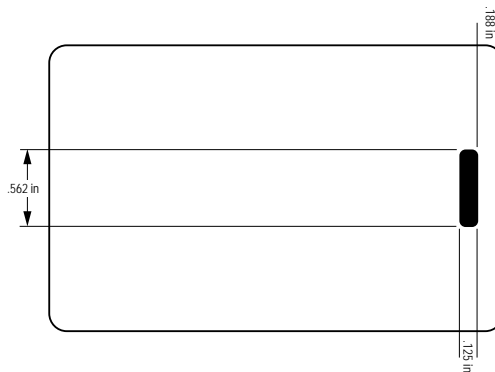

MAGNETIC STRIPE STYLES

Magnetic stripes are available in 1, 2 and 3 track configurations as shown in the dimensions drawing. Once you have chosen which configuration to use, please choose its placement on the card from the styles shown below.

Dimensions

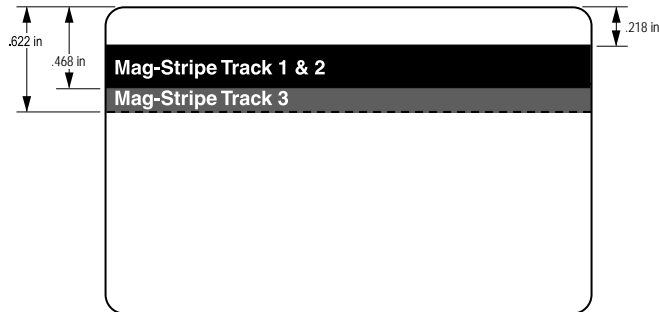

Style #1

Mag-stripe/chip opposite sides of card

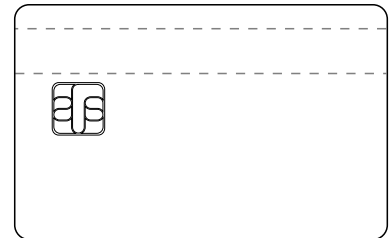

Style #2

Mag-stripe/chip opposite sides of card

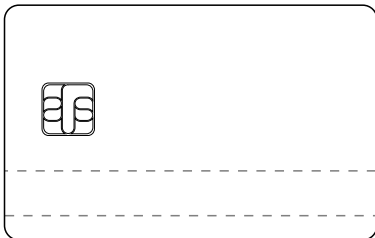

Style #3

Mag-stripe/chip on same side of card

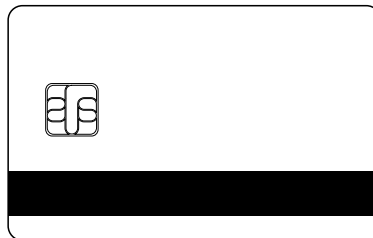

Style #4

Mag-stripe/chip on same side of card



SIGNATURE PANELS

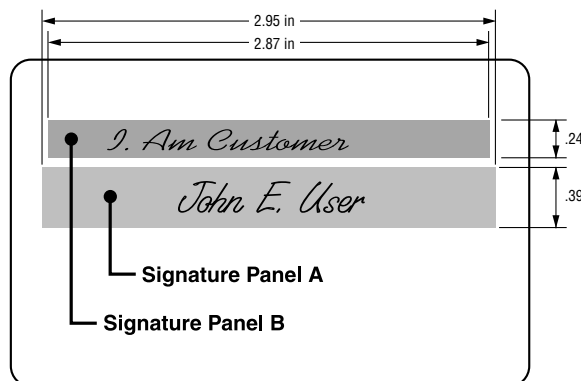

NOTES

- 1) Signature panels can be placed on any area of the card, provided that it does not overlap any other card option element such as a badge punch-out.
- 2) Unless otherwise requested, the signature panel will be placed on the back of the card.
- 3) Optional tamper-evident and custom signature panels are available.

CONTACTLESS CARDS

Contactless cards are available offering a 13.56 MHz ISO 1443 contactless smart chip embedded in ISO 7816 and 7810 compliant card. If your card uses a contactless smart chip, CardLogix requests that you specify which contactless card style you wish to use, based on the following style guide. Landscape badge punching is not recommended with contact/contactless card combinations.

Style #1
(embedded contactless chip only)

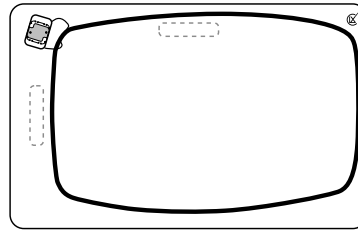

Style #2
(embedded contactless chip w/ contact chip)

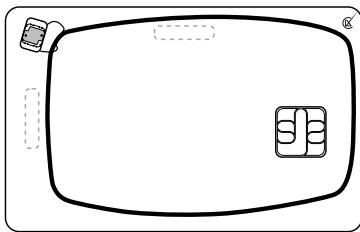

Style #3 (embedded contactless chip w/ contact chip on opposite side of card)

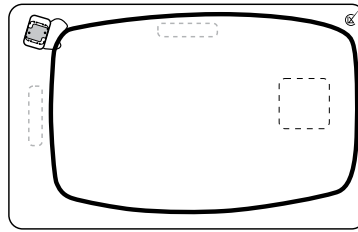

Style #4 (embedded contactless chip w/ magnetic stripe on opposite side of card)

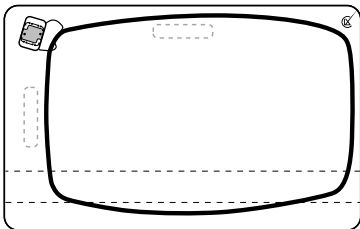

Style #5
(embedded contactless chip w/ magnetic stripe)

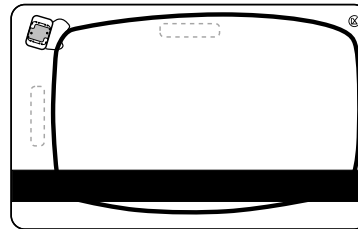

Style #6 (embedded contactless chip w/ contact chip and magnetic stripe on opposite sides of card)

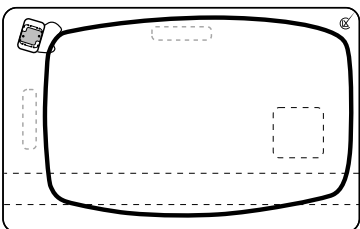

Style #7 (embedded contactless chip w/ magnetic stripe, contact chip on opposite side)

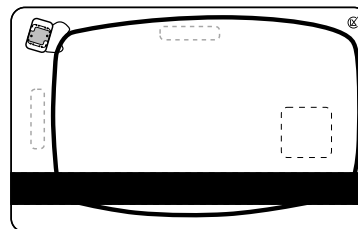

Style #8 (embedded contactless chip w/ contact chip, magnetic stripe on opposite side)

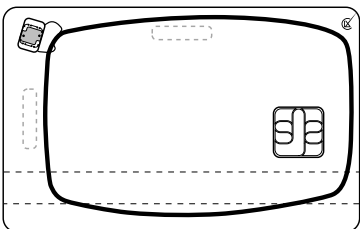

Style #9 (embedded contactless chip w/ contact chip and magnetic stripe on same side of card)

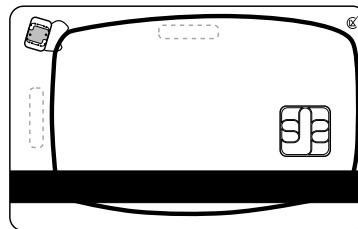

STANDARD E-PASSPORT SHEET DIMENSIONS

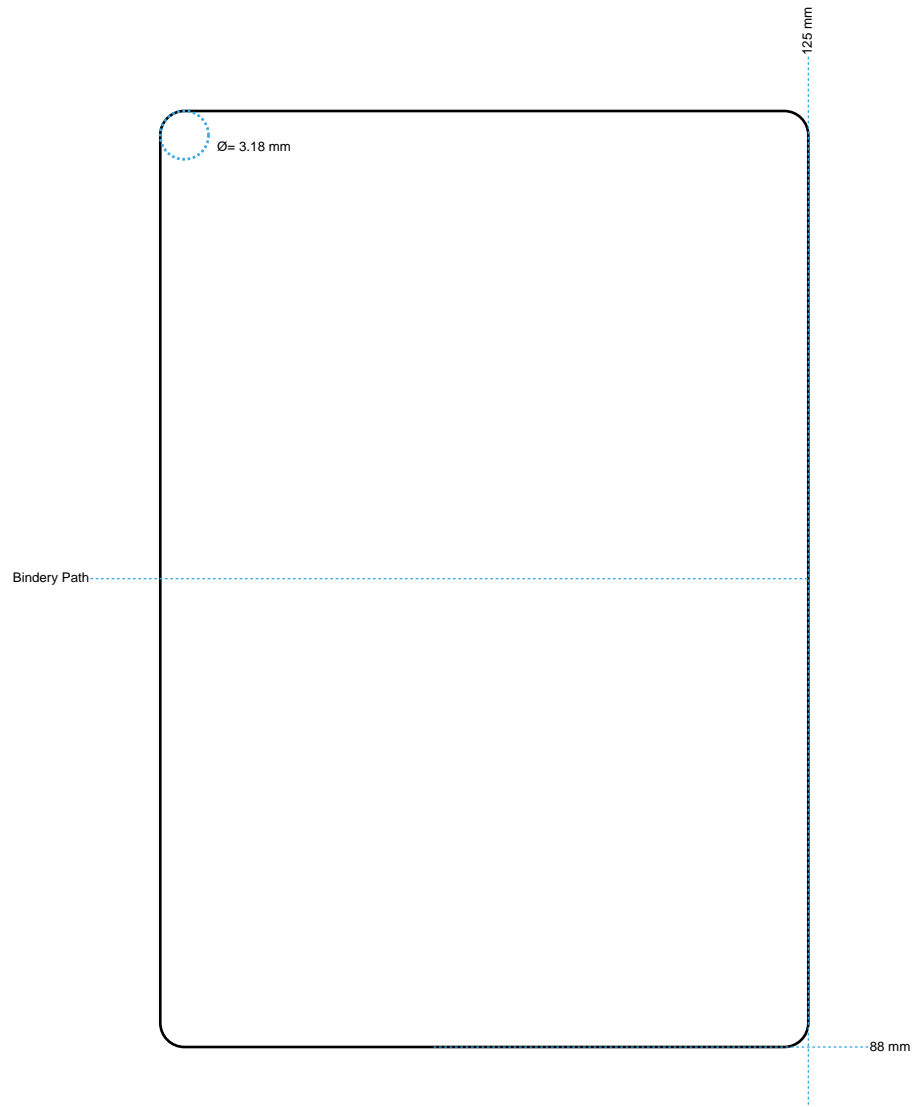

STANDARD E-PASSPORT CARD INSERT DIMENSIONS

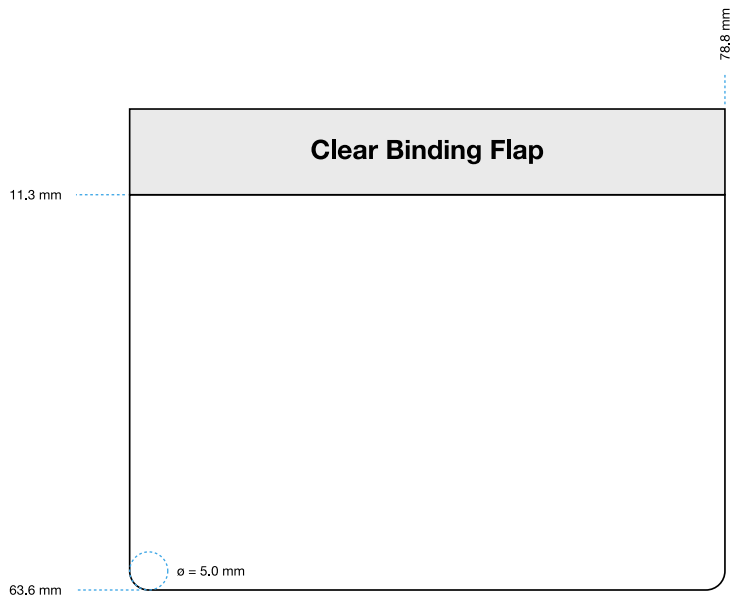

Please note that the e-passport card insert diagram is shown at 70% scale.



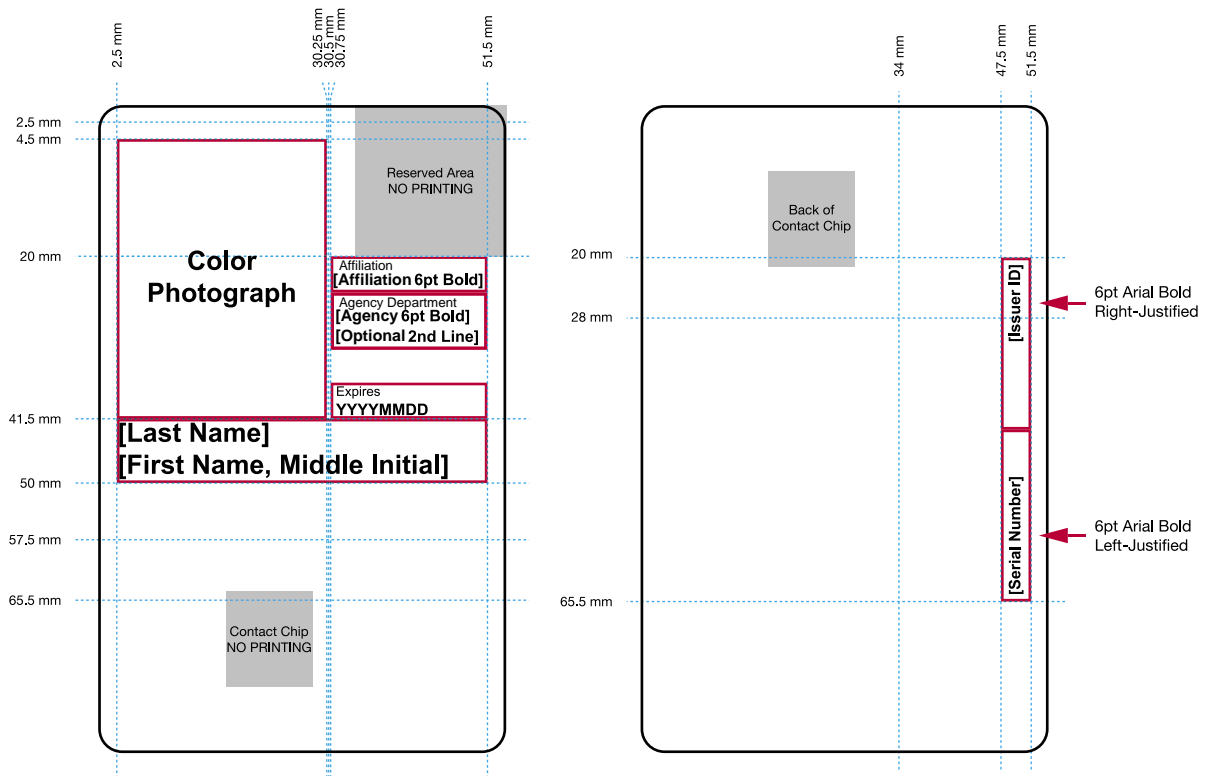





STANDARD PIV CARD TOPOLOGY



Design Tips & Suggestions

Placement of Graphics On The Card: Position your graphics no closer than 1/8" to the card edge or edge of the module. Copy should be kept out of the area in which the module will be embedded, however background images should be continuous, running through the module area. (This recommendation is to compensate for the float that comes from sheet printing and cutting and/or the poor registration of one-up card printer mechanisms).

Colors and Fonts Available For Serialization and Variable Image Printing

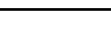
Color Name	Pantone® Equivalent	
Teal	PMS 322	
Warm Red	PMS 214	
Purple	PMS 266	
Gold	PMS 872	
Burgundy	PMS 201	
Green	PMS 349	
Blue	PMS 287	
Silver	PMS 877	
Cyan	PMS Process Cyan	
Red	PMS 200	

Available Fonts for Variable Image Printing
AvantGarde-Book/Demi
Bookman-Light/LightItalic
Bookman-Demi/Demitalic
Courier-Regular/Bold
Helvetica-Regular/Bold
NewCenturySchlbk-Roman/Bold/Italic/BoldItalic
Palatino-Roman/Italic/Bold/BoldItalic
αβγδεφγ (Symbol font)
Times New Roman-Regular/Italic/Bold/BoldItalic

Edge Bleeds: Allowing your copy to run off the edge of the card or 'bleeding' must be reflected in your artwork file by providing a representation of the card-edge in relation to the artwork. This will ensure we position your copy correctly. If artwork goes to the edge of the card, please bleed this artwork .125" off each side of the card. In this way, if the printer slightly moves, there will still be artwork to print onto your card, thus removing any chances of a white space at the edges.

Fonts: When using fonts, you should convert the fonts to curves (or outlines), in your design program. This will allow them to print accurately and without substitution. Consult your design program's documentation for instructions on how to convert fonts to curves or outlines. The exception to this rule is for serialization and variable image printing.

Proofing: CardLogix will generate an electronic proof of your artwork, which must be approved before production can begin. These proofs are for the purpose of representing the final card appearance, copy positioning and typographical accuracy, and should not be considered a 'color proof'. Please note that what you see on a computer monitor or printed sheet of paper cannot accurately represent the actual colors of the design when printed on plastic.

Colors & Color Matching: Card designs that incorporate color photographs or rasterized images will be printed using a mixture of the four primary colors Cyan, Magenta, Yellow and Black (CMYK). If the card design also contains single color elements, such as a company logo, these too will be output in CMYK color unless specifically called out in the artwork using the Pantone color matching system and requested in writing at the time we quote your project. Dark printed colors show scratches more than light colors.

Card Stock: Smart card stock is closer to 0.032" thick than 0.030". CardLogix uses the thicker material, per ISO specification, to decrease the presence of dimples on the back surface of the card, below the module. Our standard card plastic is white. Dark printed card stocks show scratches more than light colors. A photographic or light color patterned background hides these scratches best.

Card Insertion Instructions: CardLogix highly recommends the printing of directional elements to indicate to the user how to properly use the card; for example, arrows or triangles could be used to show the correct side and/or end of card to be inserted into a reader.

File Formats: It is always best to submit your graphic files to CardLogix in a vector image format as opposed to bitmap. Bitmapped or rasterized images typically do not print well.

Card Orientation: During production, CardLogix will align your artwork on the card in a standard "head-to-head" orientation as shown in the illustration below:

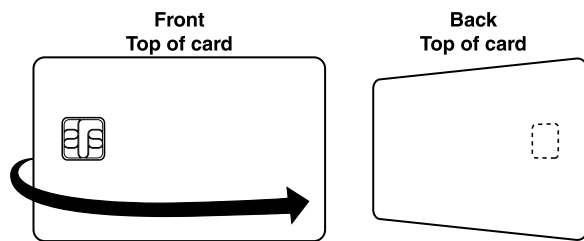

Creating Card Artwork

Implementing the best card and collateral graphics usually takes a dedicated resource or an outsourced advertising agency to create the type of files that should accompany the other investments you have in your card program. Graphics that are developed on a typical computer screen using low-end 'Paint' software or taken from a website rarely yield professional results when printed on a plastic card or a collateral piece.

The following section is designed to help your resource to produce the finest results. If your organization does not have resources readily available, CardLogix can help you through this process easily. Just call us to discuss your specific requirements.

About Graphic Files and Formats

Raster image, commonly used when reproducing photographs



Vector images, commonly used when reproducing logos, type, or line-art

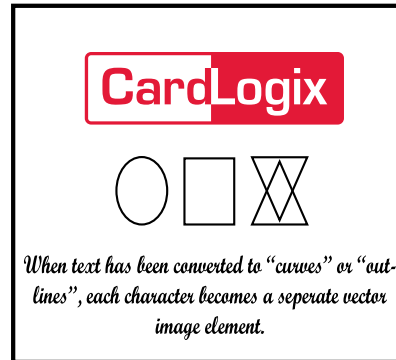

Raster Images

A raster image is comprised of colored squares called pixels. All scanners produce these types of files. These are great for photos and complex imagery with shadows, fades and 3D effects; however they should not be used to produce artwork elements that need to be printed with sharp edges or angles, such as those found in a type-face, company logo or line drawings. Examples of raster image file formats are BMP, TIFF, and JPEG. When raster image files are scaled in a graphics program there is a potential loss of quality, therefore all raster images need to be scanned in a resolution (DPI!) to suit the intended output size. When scanning photographs for use in a graphics program, use the following formula to optimize the final output quality:

(Desired final width of image ÷ original width of image) x 600 DPI = scan DPI

Once the photograph has been scanned using this formula it can be placed or imported into your vector image graphics program and scaled to the pre-determined final output size without a loss of quality DPI. Failure to prepare raster images using this formula will produce image quality problems.

Vector Images

These are made up of lines and individual shape elements that are described to the printing device as a mathematical formula. Vector images have no DPI, and because of this, may be scaled without affecting image quality. Examples of the vector image file formats are AI, EPS, and CDR. Since ALL photographic or non-continuous tone images are inherently raster images, saving a scanned image of this type as an EPS file will not make it scalable and doing so can reduce it's quality.

Setting Up Your File

The following is a simplified example of how to go about creating electronic artwork for use in production printing. CardLogix understands that no two projects are alike and that your card design may be more or less complex than what we discuss here. The information provided below is only intended as a reference, covering a more typical design process. If you are still having trouble generating a beautiful card design, please don't hesitate to consult with our staff for help.

If your artwork incorporates both raster and vector image elements, such as a product photo with your company logo laying over the top of it, we have provided the following step-by-step file preparation guide. Keep in mind that this example assumes that you are designing artwork for a standard CR-80 smart card.

- 1) Scan and save the photograph as a 600 DPI TIFF file using the CMYK color mode. Scans that have been saved using the RGB color mode will reproduce poorly. If the photograph requires resizing, use the formula provided above to determine the optimum scanner settings.
- 2) Open your graphics editing program and create a page that is 3.375" x 2.125" in size and create 2 layers.
- 3) Place or import and position your raster image file onto the first layer, then lock the layer. If the image object is intended to bleed or run off the card's edge, be sure that it extends 0.125" past each edge (it's easiest to work with a full artwork size of 3.625" x 3.375"). Remember, there is no need to create a blank area for smart chip placement.
- 4) Type any text and/or draw your vector image objects on the second layer. Convert your fonts/type to curves or outlines and be careful to keep any important copy away from the area where we will embed the smart chip. If specific colors need to be applied to any of these elements, say, to match a company logo, specify them in your file using your graphic program's Pantone® color palette. Colors specified in RGB will reproduce poorly. (Make sure that these colors are specified in a readme file when submitted).
- 5) Save/export the file as an AI or EPS file for delivery to CardLogix. We will accept artwork on standard optical discs (CD or DVD) and can also receive your artwork via a compressed e-mail attachment (ZIP, RAR, or SIT). Please refer to our comments on secure file transfer on page 4 for additional information.

Collateral

Printed pieces that carry the card, as well as associated flyers, brochures, etc. are created to coordinate with the card design and promote your card program. As card programs proliferate, collateral helps distinguish your card visually and adds impact to your program, as well as useful program information for your customer. We can help your program with many types of collateral. A few of the more popular types are illustrated below.

Carrier Documents

For mailing and distribution, the card or cards can be mounted on a piece of literature or 'carrier'. These are available in two folding styles and can be pre-printed with standard and variable data on the carrier.

Letter Fold Mailer

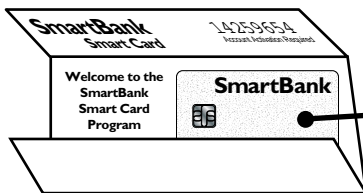

Your card can be affixed to either the top or center portions of a folded letter for mailing.

Z-Fold Mailer

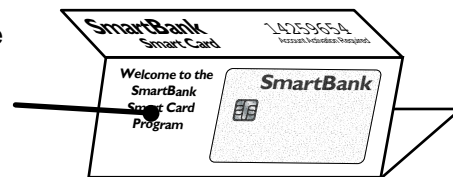

Card Sleeves & Envelopes

These carriers allow for additional text and graphics that help explain how to use the card/program and promote the program itself.

Card Wallet Book (up to 28 pages)

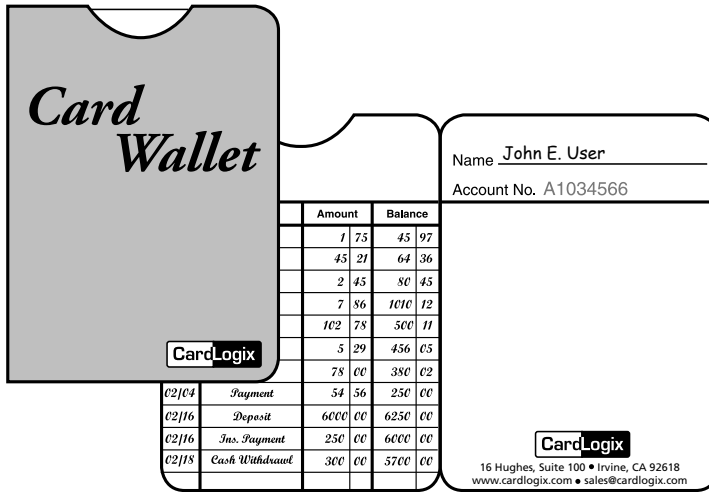

Tyvek Envelope Style A



Tyvek Envelope Style B



Blister Packaging

Retail or promotional collateral is often in the form of blister packing. The printed material and card are displayed in a clear plastic 'blister' cover that seals the card securely against a cardboard back, keeping it clean and protected. An optional punch-out window is available to allow for a barcode for activation, inventory control, etc. Please contact us for more information regarding card activation recommendations.

Blister Pack

Cards With Coupons

Coupons on cards are a proven method to increase the proposition of your card program. CardLogix offers removable coupons on our smart cards and magnetic stripe cards. Promotions combined with other card functionalities can offset or replace the cost of the whole card, adding to your bottom line.

Attracting new customers, these cards with coupons are achieving a 27% redemption rate and can be sold at an average of 40 cents each. They are designed to enhance the business of channel partners, in-house promotions, or the promotions of local businesses that have purchased coupon space. Coupons on smart cards can kick-start a sophisticated program where rechargeable coupons are reloaded into the chip after the initial labels are redeemed. Special offers and other benefits can be revealed after the coupon is peeled off. Hotels, casinos, conventions and sports venues can all profit from the cross marketing and promotional value of a CardLogix coupon card.

Use this page as a guide when planning your card package design. The shaded area at the bottom right of the illustration is an optional punch-out on the rear of the package, thus allowing a view of the back of the smart card itself.

All blisters are transparent, allowing a front view of the package contents.

Printing can extend from edge to edge, with full bleeds, and the area underneath the blister can be printed upon.

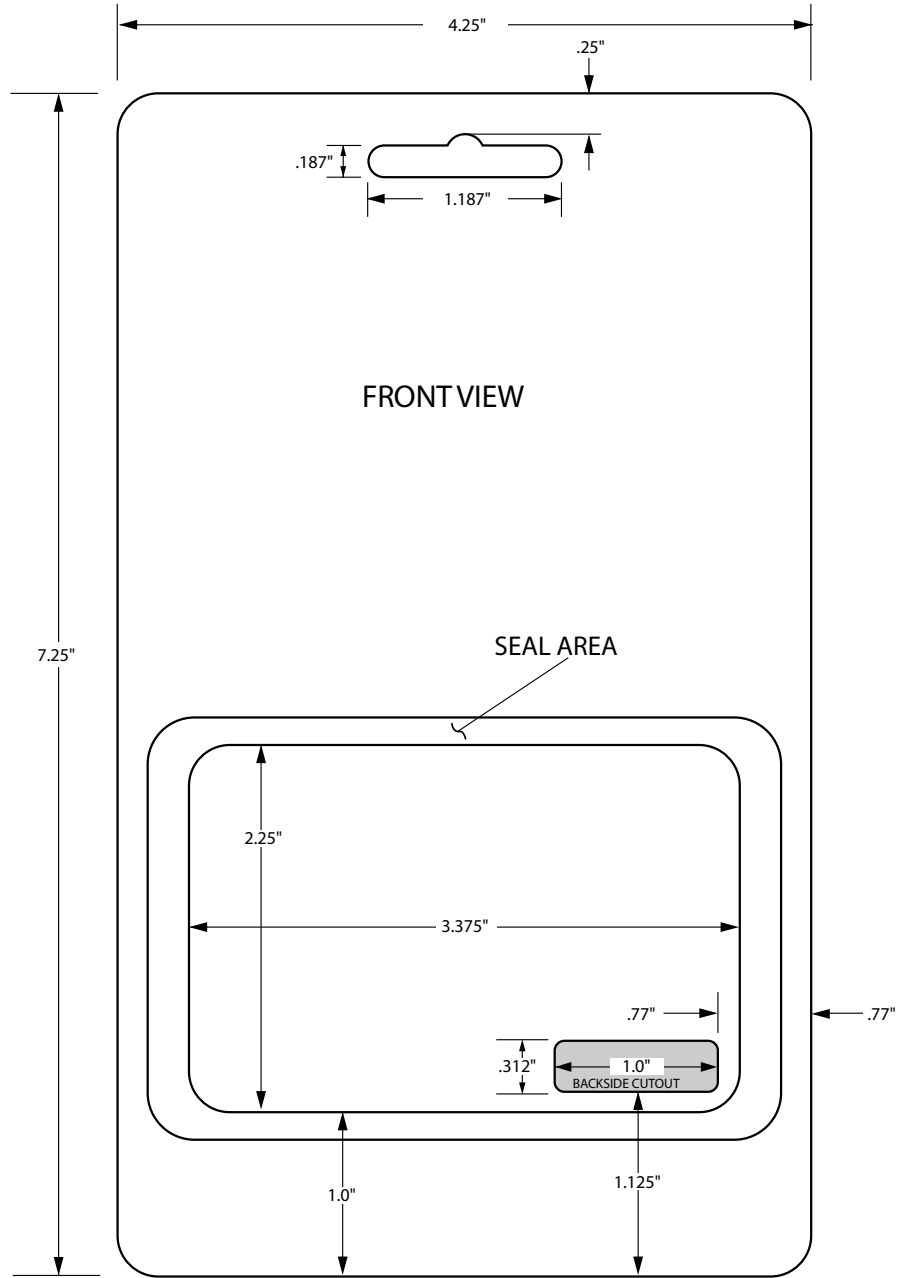

SIDE VIEW

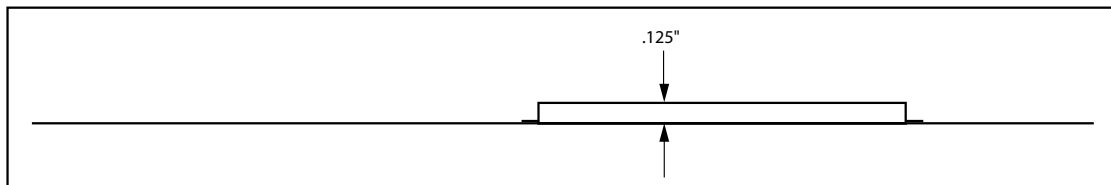

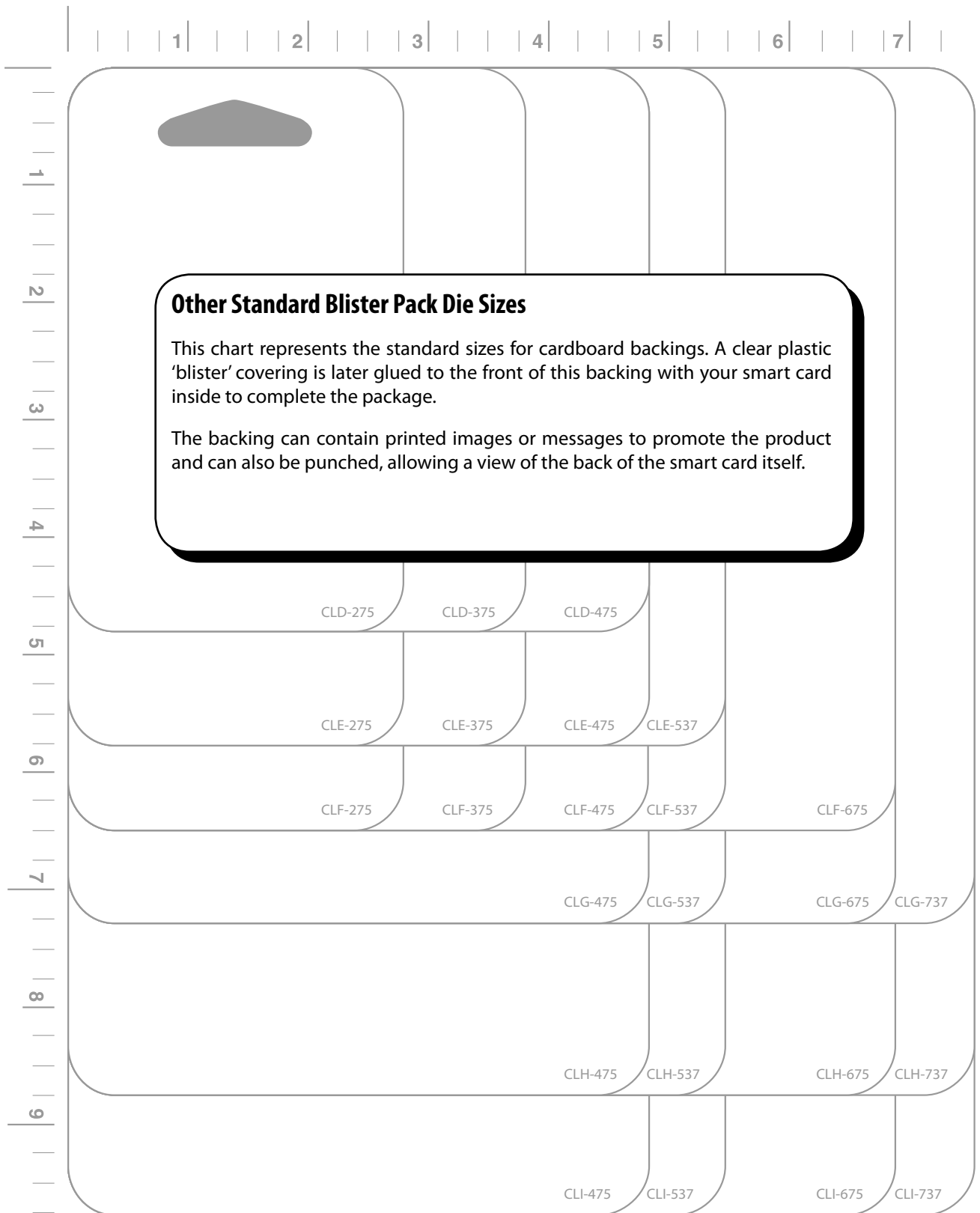

Image not to scale



Coupons affixed 4-up, on a CardLogix smart card



Coupons affixed 6-up, on a CardLogix magnetic stripe card

Artwork & File Setup Checklist

- Photographs have been scanned at 600 DPI or greater and saved in a CMYK color formatted TIFF file.
- Line-art elements have been designed in a vector drawing program such as Adobe Illustrator.
- Typographic image elements have been converted to outlines, unless the element represents the positioning of variable data.
- Spot colors have been specified using the Pantone® color matching system as well as noted in a readme file that accompanies your artwork.
- Photographic, line-art, and security elements have been logically separated using layers and meaningful layer names.
- Important image elements do not overlap the card edge and have not been positioned where the smart chip will be implanted.
- Background image elements that bleed off of the edge of the card are shown in your artwork by allowing those elements to overlap a card outline by at least .125”.
- Artwork files are collected together for submission, making sure to include a PDF or JPG file of your final artwork as a visual reference.
- All files being submitted as email attachments have been compressed to a size no larger than 10 megabytes.



**ALWAYS TAKE THE PROPER SECURITY PRECAUTIONS
WHEN DELIVERING YOUR ARTWORK.
USE ENCRYPTED EMAIL OR A SECURE COURIER!**

Glossary

Adobe PostScript® — The industry-standard page-description language invented by Adobe printing documents that integrate text, graphics, images, and color. Built into printers from over 55 major manufacturers worldwide.

Bleed / Full Bleed — Printed colors which run all the way to the edge of a card or printed material are referred to as bleeds. We charge extra for bleeds since they require the printed image to actually be slightly larger than the final trim size (requiring the use of more plastic).

Blister Pack — The process of thermally molding plastic to a specific form or shape. Often the form is attached via a glue to a paper backing. (see page X for standard dimensions) clamshell (see sample layout) designs have no backing.

Cut lines (Crop marks) — Crop marks show where a card or collateral is to be cut.

CMYK — The abbreviation for Cyan, Magenta, Yellow and Black. The printing industry uses these colors to reproduce photographic images in the printing process.

Dots Per Inch (DPI) — A unite of measurement for the resolution of a device. The higher the number, the sharper the type and images will be.

Dye Sublimation — A printing process used in plastic card printing. The ink is transferred on to the card via ribbon one color at a time. It is heated by a print head that sublimates each image into the top layer of a card. Typical resolution is 300 DPI.

Embossing — A process of forming the card or paper around type set characters or a steel rule die. Commonly used in the production of credit cards. CardLogix limits the character set to the American Bank Association formats.

Encapsulated PostScript (EPS) — A standard file format for importing and exporting PostScript language files among applications in a variety of heterogeneous environments.

Fonts — Typefaces in different styles that give documents personality. Common font technologies include the Windows True Type format and Adobe Postscript® outline fonts.

Laser Engraving — The process of cutting an image or character sequence into the surface of a card. This manufacturing process is capital-intensive, thereby reducing fraudulent reproduction.

Lithography / Offset Printing — The most common commercial printing technology in use today. Offset printing applies layers of ink on the page. For each layer, a reverse image of the page is placed on a roller in the printing press. Ink is applied to the non-image areas on the roller, so that as the roller presses against plastic moving through the press, the proper image is left on the card.

Pantone® — Pantone® Matching System, often referred to as PMS, is the most popular color matching system in the printing industry.

Pixel — The smallest dot that can be produced on a computer screen.

Prepress — The process used to turn a design from initial submission into a final form, ready for printing on a printing press. This process includes color correction, color trapping, imposition, color separation, proofing, and imagesetting.

Raster Image Processor (RIP) — The hardware and/or software that translates data from PostScript and other high-level languages into dots or pixels in a printer or imagesetter.

Resolution — The sharpness of text and graphics provided by any printer or output device, measured in dots per inch.

Screen Printing / Surface Printing — This type of printing is very common on short runs of cards and is used extensively on odd-shaped or uneven surface materials such as cardboard boxes and T-shirts. Each color has a separate screen imaged onto it. The screen is then laid on top of the object to be printed and the ink is squeegeed through each screen one color at a time. The inks cannot blend well with this process. This type of card printing is not as durable as other methods. Typical resolution is 140 DPI.

Trapping — The process of creating an overlap between adjacent colors to compensate for imprecision in the printing press.

Quality

CardLogix Corporation is absolutely committed to providing defect-free products and services to our customers, in partnership with equally committed integration partners and authorized resellers.



- California C Corporation
- CA Resale# SREAA 97-124323
- D&B# 867418899
- SIC Codes# 3577, 3089, 5162
- UNSPCSC Code# 32101617
- Harmonized Code# 8542.10.0000
- NAICS Codes# 334119, 326199, 334418, 334519, 42261, 51421
- CAGE Code# 1KV39
- Congressional District# 47